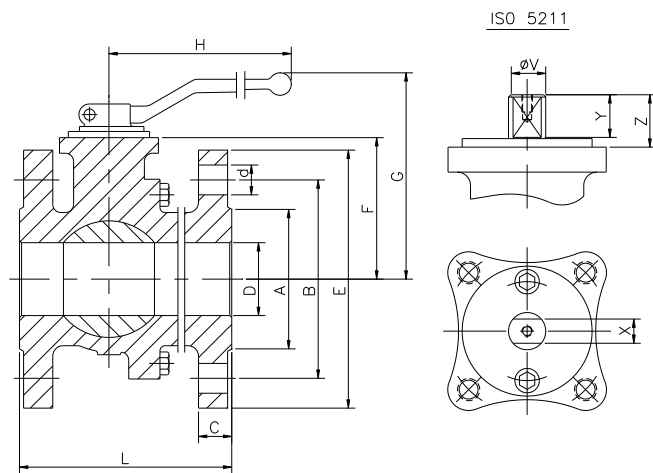
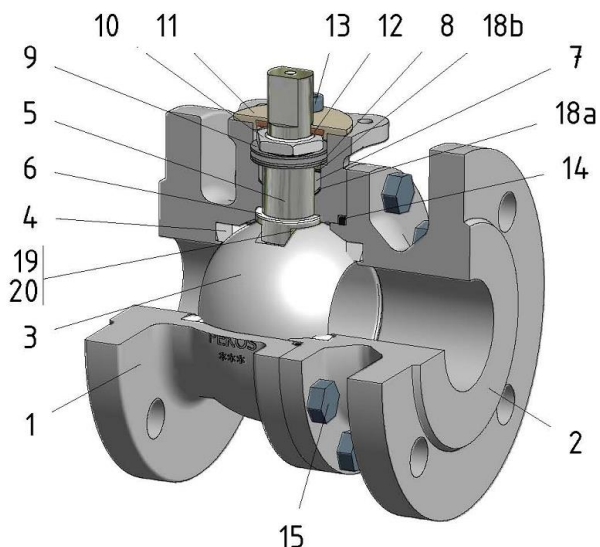

FIG. 02 RRR PN16 DN15/200 F4-F5



Position	Description	Material
01	Body 1	GGG 40
02	Body 2	GGG 40
03	Ball	S.S. 1.4408/CA15
04	Seat	PTFE (modified)+FG
05	Stem	S.S. 1.4021
06	Stem seal	PTFE (modified)+FG
07	Stem packing	PTFE (modified)+FG
08	Gland packing	S.S. 1.4401
09	Spring washer	S.S. 1.4310
10	Stem nut	S.S. 1.4305
11	Cover	S.S. 1.4408
12	Cover ring	PTFE (modified)
13	Cover bolt	A4-70
14	Body seal 1	PTFE (modified)+FG
15	Body bolt	1.045(8.8)
16	Handle	WCB
17	Handle bolt	1.045(8.8)
18	Thrust washer	PTFE (modified)+CG
19	Spring	S.S. 1.4401
20	Antistatic ball	S.S. 1.4401

General features

- Floating ball.
- Split body.
- Full bore.
- Soft seat.
- Bidirectional.
- Anti Blow out proof stem.
- Autoadjustable packing.
- Anti static device.
- Self-cavity pressure relief.

Standards

- Top flange ISO 5211
- Flanges EN 1092-02
- Face to face EN 558
- Testing EN-12266, ISO 5208
- Design EN-12516, ISO 17292

Official approvals

- ATEX 2014/34/EU
- PED 2014/68/EU
- EN 161/EN ISO 23553-1

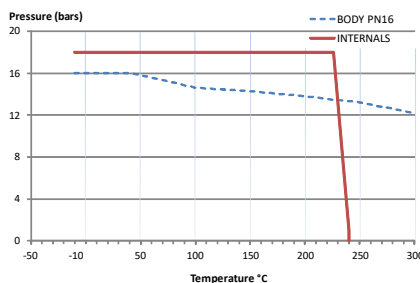

PEKOS GROUP CERTIFICATES:

ISO 9001: 2015 / 2014/68/EU / API-6D



DIMENSIONS & Technical information

DN	PN	D	L	E	A	B	C	F	H	G	V	X	Y	Z	n x d	ISO 5211	Torque	MAST	Weight
15	16	15	115	95	45	65	16	52	185	100	12	8	13	16	4 x 14	F05	10	37	3
20	16	20	120	105	58	75	18	54	185	102	12	8	13	16	4 x 14	F05	12	37	4
25	16	25	125	115	68	85	18	60	185	110	16	10	19	22	4 x 14	F05	17	80	5
32	16	32	130	140	78	100	18	65	185	115	16	10	19	22	4 x 18	F05	25	80	6
40	16	40	140	150	88	110	18	75	293	129	20	14	22	25	4 x 18	F07	37	175	8
50	16	50	150	165	102	125	20	83	293	137	20	14	22	25	4 x 18	F07	55	175	11
65	16	65	170	185	122	145	18	96	293	150	20	14	22	25	4 x 18	F07	66	175	16
80	16	80	180	200	138	160	20	114	450	187	25	19	24	27	8 x 18	F10	102	363	22
100	16	100	190	220	158	180	20	128	450	201	25	19	24	27	8 x 18	F10	132	363	27
125	16	125	325	250	188	210	22	158	680	247	34	26	35	38	8 x 18	F12	288	917	56
150	16	150	350	285	212	240	22	175	680	264	34	26	35	38	8 x 22	F12	456	917	77
200	16	201	400	340	268	295	24	245	750	334	42	32	40	43	12 x 22	F14	648	1724	134

** Depending on service conditions.

* Dimensions are in mm.

* Torque & MAST are in Nm.

* Weight is in Kilograms

* Torque values have been measured ΔP at maximum rating at room temperature