

# FIG.GKS 154 NGGVV CL900/1500 2"-2 1/2" RTJ

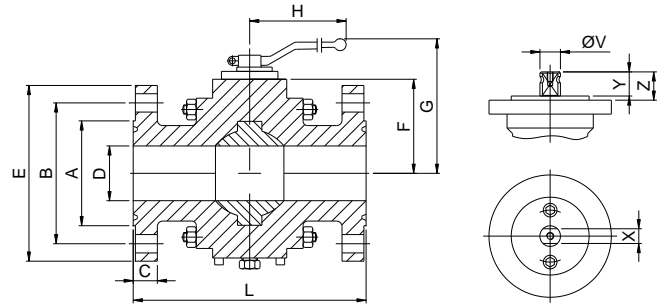
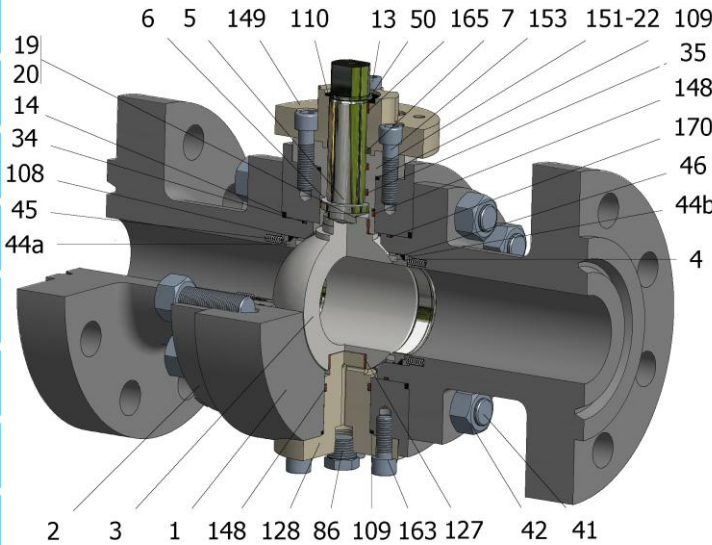

Position	Description	Material
01	Body 1	C.S. A-105
02	Body 2	C.S. A-105
03	Ball	A182 F51
04	Seat	DEVLON V
05	Stem	A182 F51
06	Stem seal	PEEK
07	Stem packing	Graphite
13	Cover bolt	S.S. (316)
14	Body seal 1	Graphite
16	Handle	WCB
17	Handle bolt	1.045(8.8)
19	Spring	Inconel X750
20	Antistatic ball	Inconel 625
22	Stop pin	S.S. AISI 316
34	Body seal 2	FKM AED
35	O ring stem	FKM AED
41	Stud	A193 L7M
42	Nut	A194 7M
44a	Ring seat 1	A182 F51
44b	Ring seat 2	A182 F51
45	Spring seat	Inconel X750
46	Seat seal	Graphite
50	Subjection ring	S.S. AISI 304
86	Drain plug	C.S. A350 LF2
86a	Vent plug	C.S. A350 LF2
108	O ring seat	FKM AED
109	Cover seal	Graphite
110	Subjection ring seal	S.S. AISI 316 Nitrided
127	Stem bearing	MU
128	Body cover 2	C.S. A-105
148	O ring cover	FKM AED
149	ISO cover	C.S. A-105
151	Body cover 1	C.S. A-105
153	ISO cover bolt	S.S. (316)
163	Body cover 2 bolt	S.S. (316)
165	Stem bearing	PTFE (modified)+FG
170	O stop seal	PTFE (modified)+CG

### General features

- Full trunnion.
- Three pieces.
- Full bore.
- Soft seat.
- Bidirectional.
- Spring loaded seat system.
- Anti Blow out proof stem.
- Anti static device.
- Self-cavity pressure relief.
- Double Block and Bleed.
- TA-LUFT.

### Standards

- Top flange ISO 5211
- Flanges ANSI B16.5
- Face to face ANSI B16.10
- Testing API 598, API 6D, BS 6755-1
- Design AP 6D, B16.34
- Materials according to NACE MR0175

### Official approvals

- CERTIFICATE FIRE SAFE API 6D.
- ATEX 2014/34/EU
- PED 2014/68/EU
- SIL 3 CAPABLE

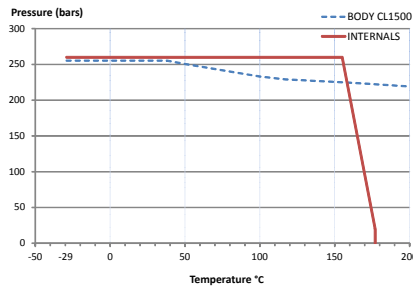

### PEKOS GROUP CERTIFICATES:



### DIMENSIONS & Technical information

DN	CL	D	L	E	A	B	C	F	H	G	V	X	Y	Z	n x d	ISO 5211	Torque	MAST	Weight
2"	1500	50	372	216	124	165	38	133	200	391	28	22	22	40	8 x 25	F10	220	1147	49
2 1/2"	1500	65	422	245	137	191	41	140	200	398	28	22	22	40	8 x 29	F10	420	1147	82

\*\* Depending on service conditions.

\* Dimensions are in mm.

\* Torque & MAST are in Nm

\* Weight is in Kilograms

\* Torque values have been measured ΔP at maximum rating at room temperature