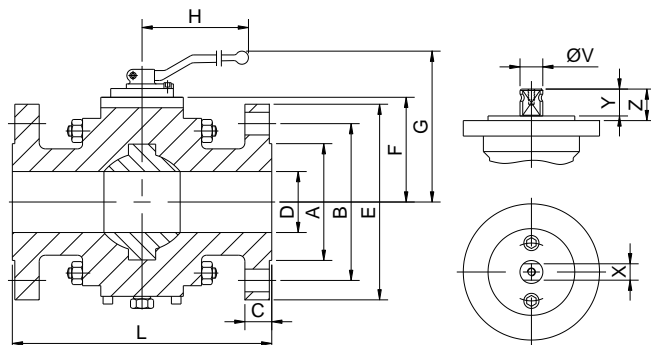
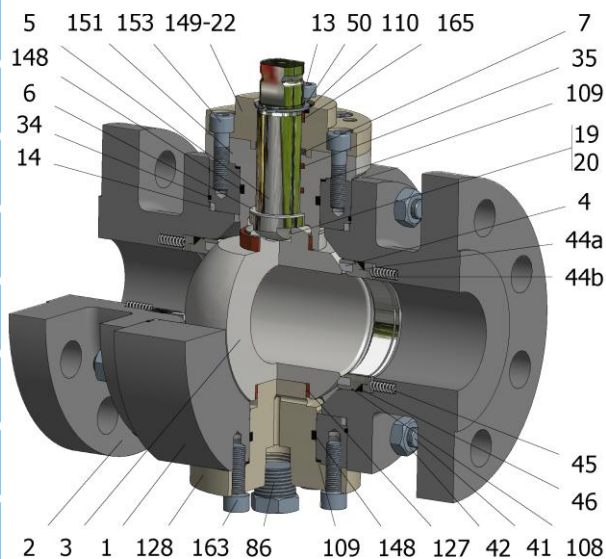

FIG.GKS 34 SGSGV CL300 2"-3"



Position	Description	Material
01	Body 1	C.S. A-105
02	Body 2	C.S. A-105
03	Ball	S.S. A351 CF8M
04	Seat	PTFE (modified)+CG
05	Stem	A182 F51
06	Stem seal	PTFE (modified)+CG
07	Stem packing	Graphite
13	Cover bolt	S.S. (316)
14	Body seal 1	PTFE (modified)+CG
16	Handle	A351 CF8M/WCB
17	Handle bolt	S.S. (304)/1.045(8.8)
19	Spring	Inconel X750
20	Antistatic ball	Inconel 625
22	Stop pin	S.S. AISI 316
34	Body seal 2	Graphite
35	O ring stem	FKM
41	Stud	A320 L7M
42	Nut	A194 7M
44a	Ring seat 1	S.S. AISI 316
44b	Ring seat 2	S.S. AISI 316
45	Spring	Inconel X750
46	Seat seal	Graphite
50	Subjection ring	S.S. AISI 420
86	Drain plug	C.S. A350 LF2
86a	Vent plug	C.S. A350 LF2
108	O ring seat	FKM
109	Cover seal	Graphite
110	Subjection ring seal	S.S. AISI 316 Nitrided
127	Stem bearing	MU
128	Body cover 2	C.S. A-105
148	O ring cover	FKM
149	ISO cover	C.S. A-105
151	Body cover 1	C.S. A-105
152	Body cover bolt	S.S. (316)
153	ISO cover bolt	S.S. (316)
163	Body cover 2 bolt	S.S. (316)
165	Stem bearing	PTFE (modified)+FG

General features

- Full trunnion.
- Three pieces.
- Full bore.
- Soft seat.
- Bidirectional.
- Spring loaded seat system.
- Anti Blow out proof stem.
- Anti static device.
- Self-cavity pressure relief.
- Double Block and Bleed.

Standards

- Top flange ISO 5211
- Flanges ANSI B16.5
- Face to face ANSI B16.10
- Testing API 598, API 6D, BS 6755-1
- Design API 6D, B16.34
- Materials according to NACE MR0175

Official approvals

- CERTIFICATE FIRE SAFE TA-LUFT VDI 2440
- ISO 15848-1
- API 6D.
- ATEX 2014/34/EU
- PED 2014/68/EU
- SIL 3 CAPABLE

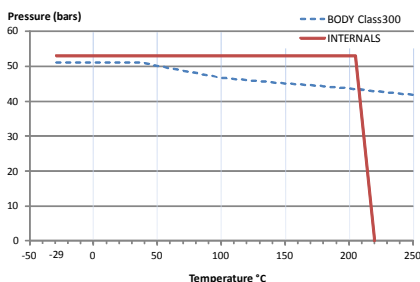

PEKOS GROUP CERTIFICATES: ISO 9001: 2015 / 2014/68/EU /API-6D



DIMENSIONS & Technical information

DN	CL	D	L	E	A	B	C	F	H	G	V	X	Y	Z	n x d	ISO 5211	Torque	MAST	Weight
2"	300	50	216	165	92	127	24	98	293	163	22	17	20	30	8 x 19	F07	85	550	25
3"	300	75	282	210	127	168	30	131	450	226	28	22	22	40	8 x 22	F10	210	1147	36

** Depending on service conditions.

* Dimensions are in mm. * Torque & MAST are in Nm * Weight is in Kilograms

* Torque values have been measured ΔP at maximum rating at room temperature