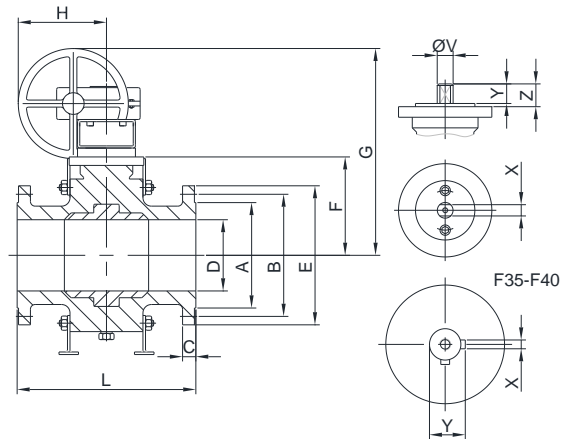
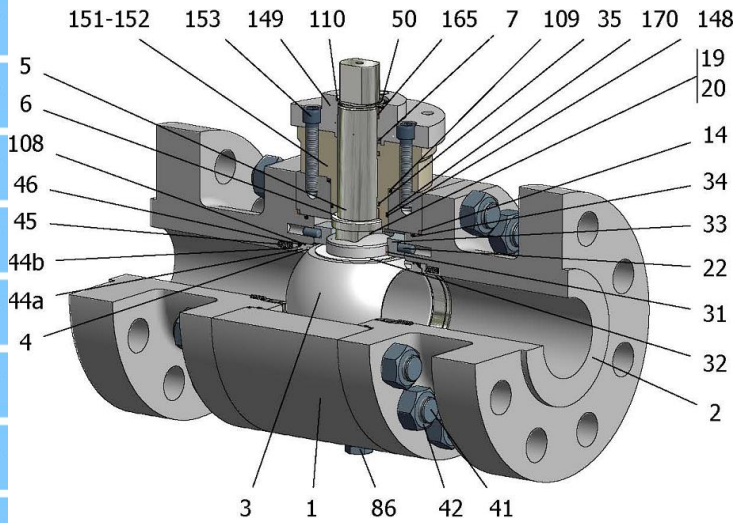

FIG.GKS 909 NGGVV CL900 3"-20"



Position	Description	Material
01	Body 1	C.S. A350 LF2
02	Body 2	C.S. A350 LF2
03	Ball	A182 F316
04	Seat	DEVLON V
05	Stem	A182 F51
06	Stem seal	PEEK
07	Stem packing	Graphite
14	Body seal 1	Graphite
19	Spring	Inconel X750
20	Antistatic ball	Inconel 625
22	Stop pin	S.S. AISI 316
31	Bearing	MU
32	Bearing disk	PTFE (modified)+FG
33	Support bearing	S275JR+ENP
34	Body seal 2	FKM
35	O ring stem	FKM
41	Stud	A320 L7M
42	Nut	A194 7M
44a	Ring seat 1	S.S. AISI 316
44b	Ring seat 2	S.S. AISI 316
45	Spring	Inconel X750
46	Seat seal	Graphite
50	Subjection ring	S.S. AISI 420
86	Drain plug	C.S. A350 LF2
86a	Vent plug	C.S. A350 LF2
108	O ring seat	FKM
109	Cover seal	Graphite
110	Subjection ring seal	S.S. AISI 316 Nitrided
148	O ring cover	FKM
149	ISO cover	C.S. A350 LF2
151	Body cover 1	C.S. A350 LF2
152	Body cover bolt	S.S. (316)
153	ISO cover bolt	S.S. (316)
165	Stem bearing	PTFE (modified)+FG
170	O stop seal	PTFE (modified)+CG

General features

- Full trunnion.
- Three pieces.
- Full bore.
- Soft seat.
- Bidirectional.
- Spring loaded seat system.
- Anti Blow out proof stem.
- Anti static device.
- Self-cavity pressure relief.
- Double Block and Bleed.

Standards

- Top flange ISO 5211
- Flanges ANSI B16.5
- Face to face ANSI B16.10
- Testing API 598, API 6D, BS 6755-1
- Design API 6D, B16.34
- Materials according to NACE MR0175

Official approvals

- CERTIFICATE FIRE SAFE TA-LUFT VDI 2440
- ISO 15848-1
- API 6D.
- ATEX 2014/34/EU
- PED 2014/68/EU
- SIL 3 CAPABLE

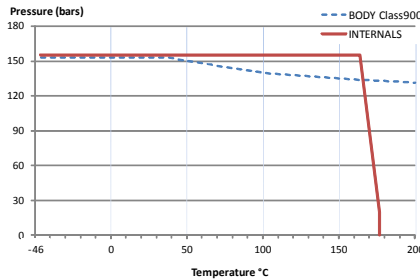

PEKOS GROUP CERTIFICATES: ISO 9001: 2015 / 2014/68/EU /API-6D



DIMENSIONS & Technical information

DN	CL	D	L	E	A	B	C	F	H	G	V	X	Y	Z	n x d	ISO 5211	Torque	MAST	Weight
3"	900	75	381	240	127	191	44	160	271	481	36	27	35	50	8 x 25	F12	420	2356	105
4"	900	100	457	290	157	235	51	175	336	547	36	27	35	50	8 x 32	F12	645	2356	165
6"	900	150	610	380	216	318	62	229	486	657	48	36	40	63	12 x 32	F14	1525	5585	380
8"	900	201	737	470	270	394	70	295	511	650	48	36	40	63	12 x 38	F16-1	2380	5585	640
10"	900	252	838	545	324	470	76	330	511	685	48	36	40	63	16 x 38	F16-1	3010	5585	952
12"	900	303	965	610	381	533	86	400	613	809	72	55	70	83	20 x 38	F25	3570	19103	1312
14"	900	322	1029	640	413	559	92	436	613	845	72	55	70	83	20 x 41	F25	6075	19103	1595
16"	900	373	1130	705	470	616	95	476	628	885	72	55	70	83	20 x 45	F30-1	8080	19103	1962
18"	900	423	1219	785	527	686	108	511	831	906	98	75	100	106	20 x 51	F30	12670	48235	2755
20"	900	471	1321	855	584	749	114	585	**	**	120	32	127	200	20 x 54	F35	17740	29160	3752

** Depending on service conditions.

* Dimensions are in mm.

* Torque & MAST are in Nm

* Weight is in Kilograms

* Torque values have been measured ΔP at maximum rating at room temperature