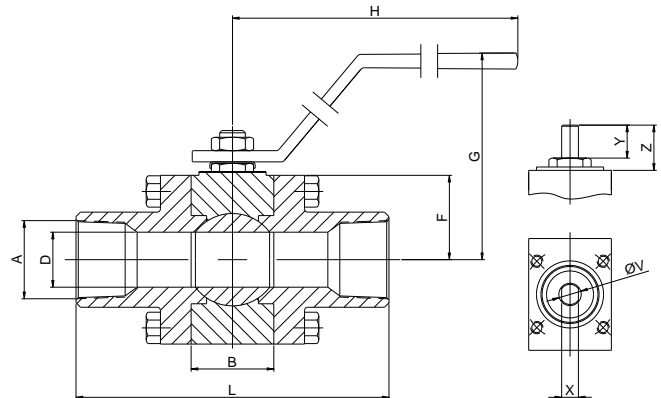
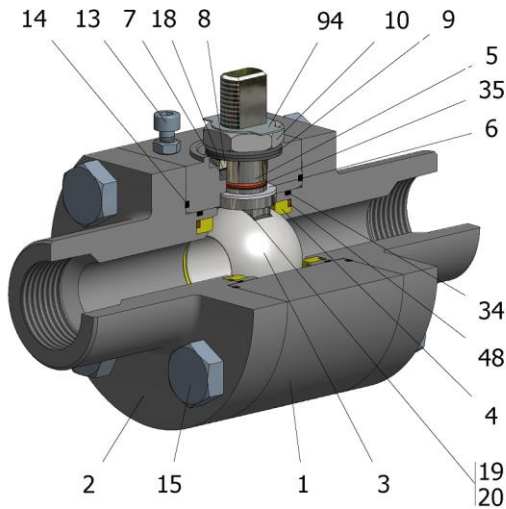

FIG.K 259 NGGVV CL2500 1/4"-1" NPT



Position	Description	Material
01	Body 1	C.S. A350 LF2/A-105
02	Body 2	C.S. A350 LF2/A-105
03	Ball	A182 F316/316L
04	Seat	DEVLON V
05	Stem	S.S. AISI 316/316L
06	Stem seal	PEEK
07	Stem packing 1	Graphite
08	Gland packing	S.S. AISI 316
09	Spring washer	S.S. AISI 301
10	Stem nut	S.S. AISI 304
13	Cover bolt	S.S. (316)
14	Body seal 1	Graphite
15	Body bolt	A320 L7M
16	Handle	WCB
17	Handle bolt	1.045(8.8)
18	Thrust washer	PTFE (modified)+CG
19	Spring	S.S. AISI 316
20	Antistatic ball	S.S. AISI 316
34	Body seal 2	FKM
35	O ring stem	FKM
48	Seat seal	FKM
94	Stop washer	S.S. AISI 304

General features

- Floating ball.
- Three pieces.
- Full bore.
- Soft seat.
- Bidirectional.
- Anti Blow out proof stem.
- Autoadjustable packing.
- Anti static device.
- Self-cavity pressure relief.

Standards

- Top flange ISO 5211
- Threaded ends NPT
- Materials according to NACE MR0175

Official approvals

- CERTIFICATE FIRE SAFE
- ATEX 2014/34/EU
- PED 2014/68/EU
- SIL 3 CAPABLE

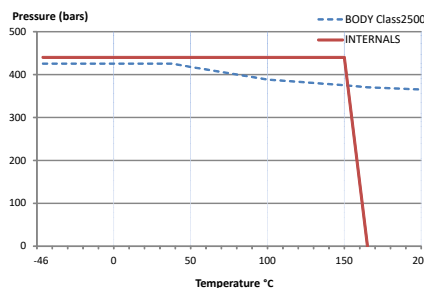

PEKOS GROUP CERTIFICATES:

ISO 9001: 2015 / 2014/68/EU /API-6D



DIMENSIONS & Technical information

DN	CL	D	L	E	A	B	C	F	H	G	V	X	Y	Z	n x d	ISO 5211	Torque	MAST	Weight
1/4"	2500	11,1	100	-	1/4"	34	-	31	180	98	12	7,5	10	14	- x -	F03	14	17	3
3/8"	2500	11,1	100	-	3/8"	34	-	31	180	98	12	7,5	10	14	- x -	F03	14	17	3
1/2"	2500	11,1	100	-	1/2"	34	-	31	180	98	12	7,5	10	14	- x -	F03	14	17	3
3/4"	2500	15,5	127	-	3/4"	37	-	41	180	108	12	7,5	11	12	- x -	F04	29	34	5
1"	2500	21	140	-	1"	44	-	46	220	117	15	9	17	21	- x -	F05	55	65	6

** Depending on service conditions.

* Dimensions are in mm. * Torque & MAST are in Nm * Weight is in Kilograms

* Torque values have been measured ΔP at maximum rating at room temperature