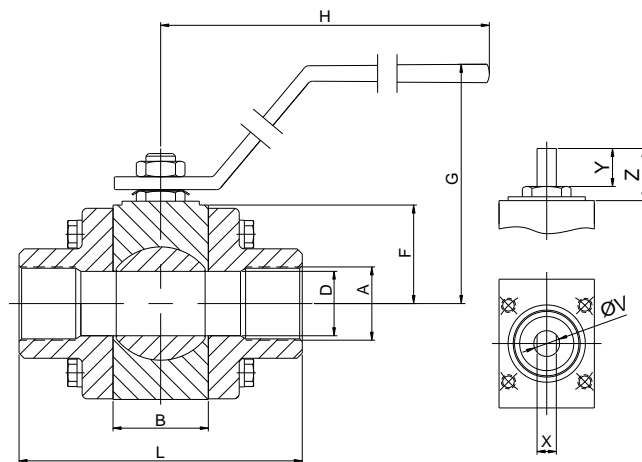
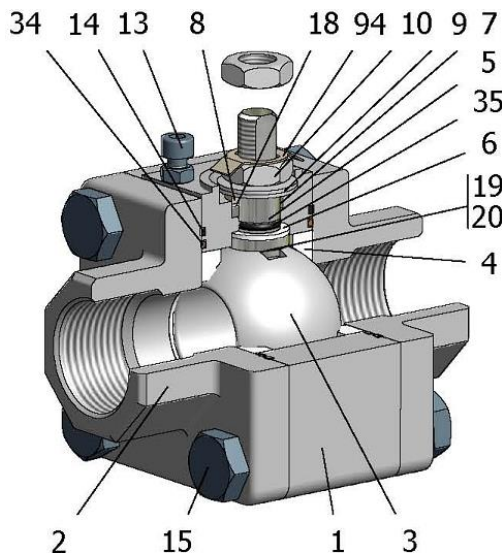

FIG.K 806 SGGVV CL800 1/4"-1 1/2" BSPP



Position	Description	Material
01	Body 1	S.S. AISI 316L
02	Body 2	S.S. AISI 316L
03	Ball	S.S. AISI 316/316L
04	Seat	PTFE (modified)+CG
05	Stem	S.S. AISI 316/316L
06	Stem seal	PTFE (modified)+CG
07	Stem packing	Graphite
08	Gland packing	S.S. AISI 316
09	Spring washer	S.S. AISI 301
10	Stem nut	S.S. AISI 304
13	Stop bolt	S.S. (316)
14	Body seal 1	Graphite
15	Body bolt	A193 B8M
16	Handle	PAINTED C.S.
18	Thrust washer	PTFE (modified)+CG
19	Spring	S.S. AISI 316
20	Antistatic ball	S.S. AISI 316
34	Body seal 2	FKM
35	O ring stem	FKM
94	Stop washer	S.S. AISI 301

General features

- Three pieces.
- Full bore.
- Soft seat.
- Bidirectional.
- Anti Blow out proof stem.
- Autoadjustable packing.
- Anti static device.
- Self-cavity pressure relief.
- Allows in-line maintenance
- Floating ball.

Standards

- Top flange ISO 5211
- Threaded ends BSPP
- Materials according to NACE MR0175
- Design B16.34
- Testing API 598, BS 6755-1

Official approvals

- CERTIFICATE FIRE SAFE
- ATEX 2014/34/EU
- PED 2014/68/EU
- SIL 3 CAPABLE

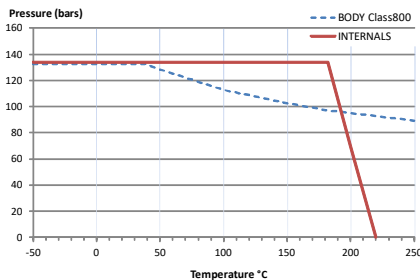

PEKOS GROUP CERTIFICATES: ISO 9001: 2015 / 2014/68/EU /API-6D

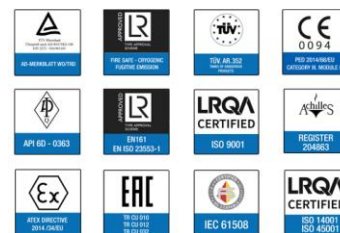

DIMENSIONS & Technical information

DN	CL	D	L	E	A	B	C	F	H	G	V	X	Y	Z	n x d	ISO 5211	Torque	MAST	Weight
1/4"	800	11	75	-	1/4"	19	-	31	145	82	10	5,5	7	9	- x -	F03	9	17	1
3/8"	800	11	75	-	3/8"	19	-	31	145	82	10	5,5	7	9	- x -	F03	9	17	1
1/2"	800	15	80	-	1/2"	21	-	34	145	85	10	5,5	8	10	- x -	F03	12	17	1
3/4"	800	21	100	-	3/4"	28	-	39	180	101	12	7,5	11	14	- x -	F04	18	34	2
1"	800	25	110	-	1"	37	-	38	180	105	12	7,5	14	20	- x -	F04	25	34	3
1 1/4"	800	32	120	-	1 1/4"	44	-	41	220	108	15	9	18	26	- x -	F05	30	65	4
1 1/2"	800	38	140	-	1 1/2"	51	-	47	220	110	15	9	18	28	- x -	F05	35	65	6

** Depending on service conditions.

* Dimensions are in mm. * Torque & MAST are in Nm * Weight is in Kilograms

* Torque values have been measured ΔP at maximum rating at room temperature