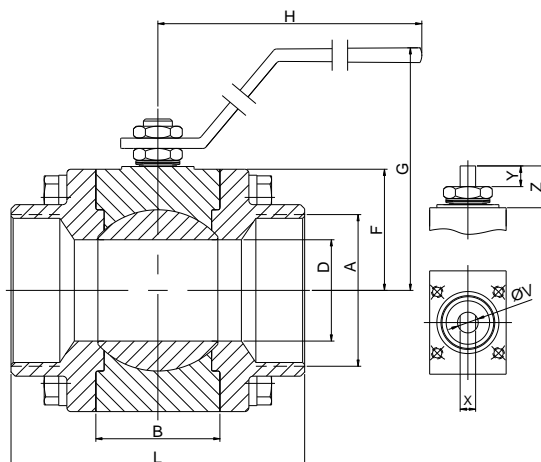
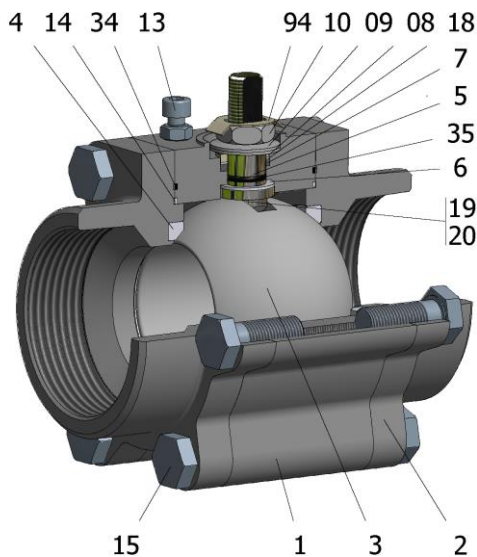

FIG.KRB 806 SGSGV CL600 2 1/2"-3" BSPP



Position	Description	Material
01	Body 1	A182 F316/316L
02	Body 2	A182 F316/316L
03	Ball	A182 F316/316L
04	Seat	PTFE (modified)+CG
05	Stem	S.S. AISI 316/316L
06	Stem seal	PTFE (modified)+CG
07	Stem packing	Graphite
08	Gland packing	S.S. AISI 316
09	Spring washer	S.S. AISI 301
10	Stem nut	S.S. AISI 304
13	Stop bolt	S.S. (316)
14	Body seal 1	PTFE (modified)+CG
15	Body bolt	A193 B8M
16	Handle	PAINTED C.S.
18	Thrust washer	PTFE (modified)+CG
19	Spring	S.S. AISI 316
20	Antistatic ball	S.S. AISI 316
34	Body seal 2	Graphite
35	O ring stem	FKM
94	Stop washer	S.S. AISI 301

General features

- Three pieces.
- Reduced bore.
- Soft seat.
- Bidirectional.
- Anti Blow out proof stem.
- Autoadjustable packing.
- Anti static device.
- Self-cavity pressure relief.
- Floating ball.

Standards

- Top flange ISO 5211
- Threaded ends BSPP
- Materials according to NACE MR0175
- Design B16.34
- Testing API 598, BS 6755-1

Official approvals

- CERTIFICATE FIRE SAFE
- ATEX 2014/34/EU
- PED 2014/68/EU
- SIL 3 CAPABLE

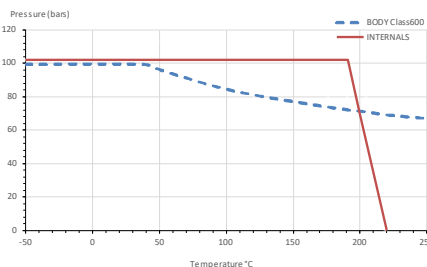

PEKOS GROUP CERTIFICATES:

ISO 9001: 2015 / 2014/68/EU / API-6D

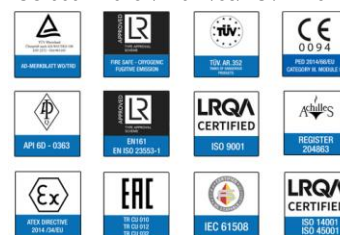

DIMENSIONS & Technical information

DN	CL	D	L	E	A	B	C	F	H	G	V	X	Y	Z	n x d	ISO 5211	Torque	MAST	Weight
2 1/2"	600	49	142	-	2 1/2"	60	-	58	220	119	15	9	16	24	- x -	F05	-	65	10
3"	600	62	170	-	3"	72	-	70	425	143	22	16	22	31	- x -	F07	-	234	14

** Depending on service conditions.

* Dimensions are in mm. * Torque & MAST are in Nm * Weight is in Kilograms

* Torque values have been measured ΔP at maximum rating at room temperature