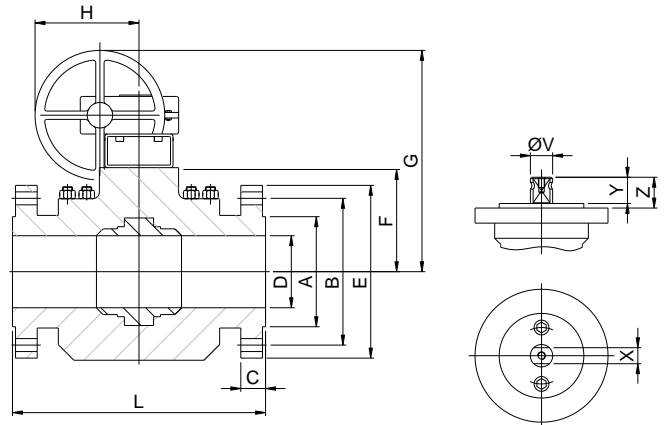
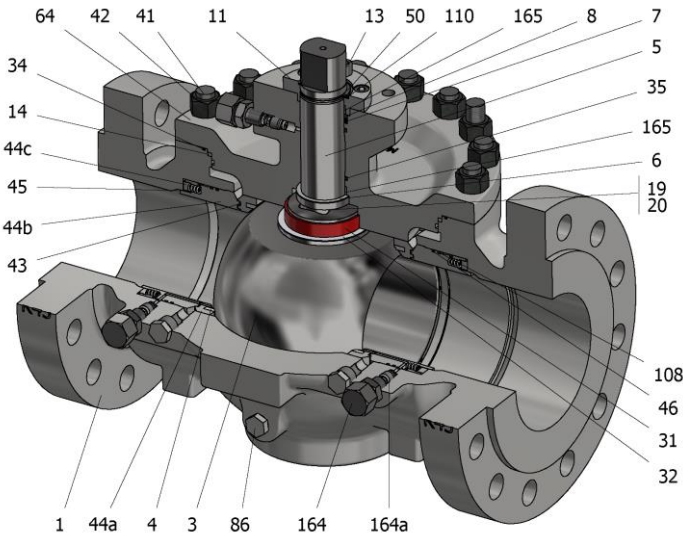

FIG.TEGS 19 SGSGV CL150 6"-12"



Position	Description	Material
01	Body 1	C.S. A352 LCC
03	Ball	S.S. A351 CF8M
04	Seat	PTFE (modified)+CG
05	Stem	A182 F51
06	Stem seal	PTFE (modified)+CG
07	Stem packing	Graphite
08	Gland packing	S.S. AISI 316
11	Cover	S.S. A351 CF8M
13	Cover bolt	S.S. (316)
14	Body seal 1	PTFE (modified)+CG
19	Spring	Inconel X750
20	Antistatic ball	Inconel 625
31	Bearing	MU
32	Bearing disk	PTFE (modified)+FG
34	Body seal 2	Graphite
35	Stem O ring	FKM
41	Stud	A320 L7M
42	Nut	A194 7M
43	Seat seal	Graphite+AISI 316
44a	Ring seat 1	S.S. AISI 316
44b	Ring seat 2	S.S. AISI 316
44c	Ring seat 3	S.S. AISI 316
45	Spring	Inconel X750
46	Seat seal	Graphite
50	Subjection ring	S.S. AISI 420
64	Body cover	C.S. A352 LCC
86	Plug	C.S. A350 LF2
108	Seat O ring	FKM
110	Subjection ring seal	S.S. AISI 316 Nitrided
164	Grease cup	S.S. AISI 316
164a	Check valve	S.S. AISI 316
165	Stem bearing	MU

General features

- Full trunnion.
- Top entry
- Full bore.
- Soft seat.
- Bidirectional.
- Spring loaded seat system.
- Anti Blow out proof stem.
- Anti static device.
- Self-cavity pressure relief.
- Double Block and Bleed.
- Allows in-line maintenance

Standards

- Top flange ISO 5211
- Flanges ANSI B16.5
- Face to face ANSI B16.10 (CLASS 600)
- Testing API 598, API 6D, BS 6755-1
- Design API 6D, B16.34
- Materials according to NACE MR0175

Official approvals

- CERTIFICATE FIRE SAFE
- TA-LUFT VDI 2440
- ISO 15848-1
- ATEX 2014/34/EU
- API 6D.
- PED 2014/68/EU
- SIL 3 CAPABLE

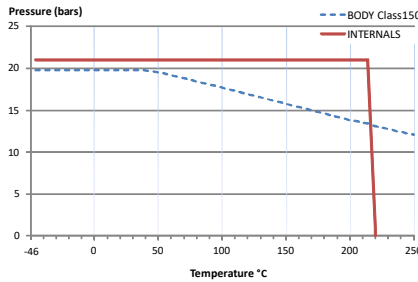

PEKOS GROUP CERTIFICATES:



DIMENSIONS & Technical information

DN	CL	D	L	E	A	B	C	F	H	G	V	X	Y	Z	n x d	ISO 5211	Torque	MAST	Weight
6"	150	150	559	280	216	241	26	223	271	544	36	27	35	50	8 x 22	F12	450	2356	160
8"	150	201	660	345	270	299	29	279	336	661	48	36	40	63	8 x 22	F14	695	5585	280
10"	150	252	787	405	324	362	31	310	336	647	48	36	40	63	12 x 25	F14	940	5585	375
12"	150	303	838	485	381	432	33	358	355	656	60	46	60	73	12 x 25	F16	1160	11084	550

\*\* Depending on service conditions.

\* Dimensions are in mm.

\* Torque & MAST are in Nm

\* Weight is in Kilograms

\* Torque values have been measured ΔP at maximum rating at room temperature