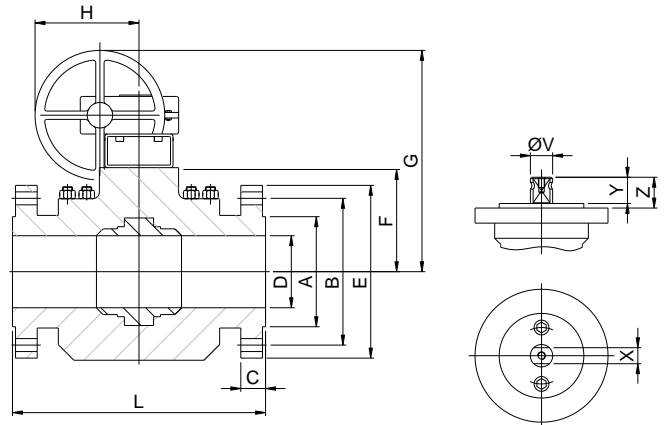
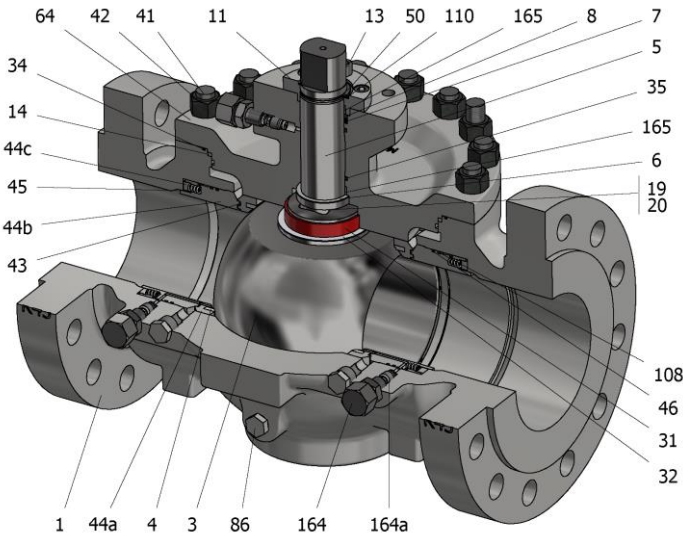

FIG.TEGS 64 SGSGV CL600 6"-12"



Position	Description	Material
01	Body 1	C.S. A216 WCC
03	Ball	S.S. A351 CF8M
04	Seat	PTFE (modified)+CG
05	Stem	A182 F51
06	Stem seal	PEEK
07	Stem packing	Graphite
08	Gland packing	S.S. AISI 316
11	Cover	S.S. A351 CF8M
13	Cover bolt	S.S. (316)
14	Body seal 1	PTFE (modified)+CG
19	Spring	Inconel X750
20	Antistatic ball	Inconel 625
31	Bearing	MU
32	Bearing disk	PTFE (modified)+FG
34	Body seal 2	Graphite
35	Stem O ring	FKM
41	Stud	A320 L7M
42	Nut	A194 7M
43	Seat seal	Graphite+AISI 316
44a	Ring seat 1	S.S. AISI 316
44b	Ring seat 2	S.S. AISI 316
44c	Ring seat 3	S.S. AISI 316
45	Spring	Inconel X750
46	Seat seal	Graphite
50	Subjection ring	S.S. AISI 420
64	Body cover	C.S. A216 WCC
86	Plug	C.S. A350 LF2
108	Seat O ring	FKM
110	Subjection ring seal	S.S. AISI 316 Nitrided
164	Grease cup	S.S. AISI 316
164a	Check valve	S.S. AISI 316
165	Stem bearing	MU

General features

- Full trunnion.
- Top entry
- Full bore.
- Soft seat.
- Bidirectional.
- Spring loaded seat system.
- Anti Blow out proof stem.
- Anti static device.
- Self-cavity pressure relief.
- Double Block and Bleed.
- Allows in-line maintenance

Standards

- Top flange ISO 5211
- Flanges ANSI B16.5
- Face to face ANSI B16.10 (CLASS 600)
- Testing API 598, API 6D, BS 6755-1
- Design API 6D, B16.34
- Materials according to NACE MR0175

Official approvals

- CERTIFICATE FIRE SAFE
- TA-LUFT VDI 2440
- ISO 15848-1
- ATEX 2014/34/EU
- API 6D.
- PED 2014/68/EU
- SIL 3 CAPABLE

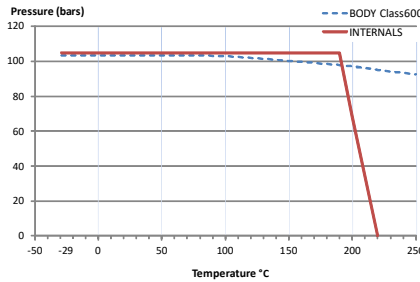

PEKOS GROUP CERTIFICATES:



DIMENSIONS & Technical information

DN	CL	D	L	E	A	B	C	F	H	G	V	X	Y	Z	n x d	ISO 5211	Torque	MAST	Weight
6"	600	150	559	355	216	292	55	236	436	614	48	36	40	63	12 x 28,5	F14	1110	5585	225
8"	600	201	660	420	270	349	63	279	461	584	48	36	40	63	12 x 32	F16-1	1750	5585	400
10"	600	252	787	510	324	432	70,5	310	461	615	48	36	40	63	16 x 35	F16-1	2215	5585	585
12"	600	303	838	560	381	489	74	383	461	688	72	55	70	83	20 x 35	F25	2640	19103	820

** Depending on service conditions.

* Dimensions are in mm.

* Torque & MAST are in Nm

* Weight is in Kilograms

* Torque values have been measured ΔP at maximum rating at room temperature