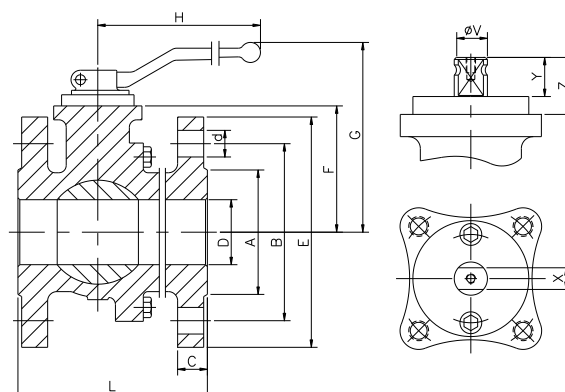
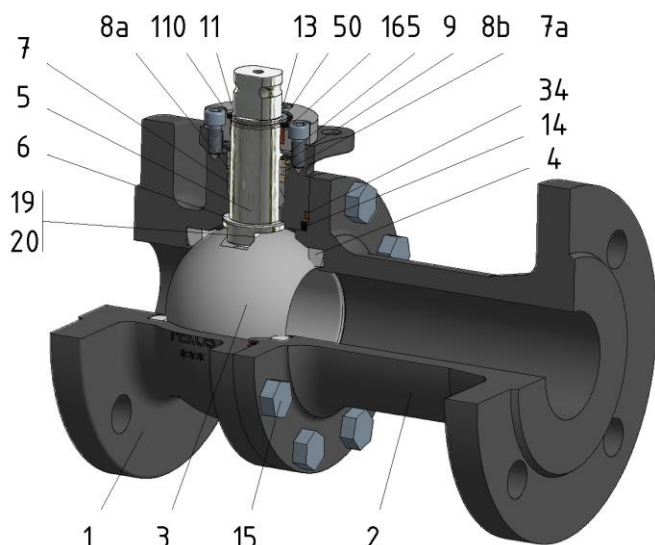

FIG.Z 27 TTTG PN40 DN15/125 F1



Position	Description	Material
01	Body 1	S.S. 1.4539
02	Body 2	S.S. 1.4539
03	Ball	S.S. 1.4539
04	Seat	PTFE (modified)
05	Stem	S.S. 1.4539
06	Stem seal	PTFE (modified)+FG
07	Stem packing	PTFE (modified)
07a	Stem packing 2	Graphite
08a	Gland packing 1	S.S. 1.4401
08b	Gland packing 2	S.S. 1.4401
09	Spring washer	S.S. 1.4310
11	Cover	S.S. 1.4408
13	Cover bolt	A4-70
14	Body seal 1	PTFE (modified)
15	Body bolt	A4-70
16	Handle	WCB
17	Handle bolt	1.045(8.8)
19	Spring	S.S. 1.4401
20	Antistatic ball	S.S. 1.4401
34	Body seal 2	Graphite
50	Subjection ring	S.S. 1.4301
110	Subjection ring seal	S.S. 1.4401 Nitrided
165	Stem bearing	PTFE (modified)+FG

General features

- Floating ball.
- Split body.
- Full bore.
- Soft seat.
- Bidirectional.
- Anti Blow out proof stem.
- Autoadjustable packing.
- Anti static device.
- Self-cavity pressure relief.

Standards

- Top flange ISO 5211
- Flanges EN 1092-01
- Face to face EN 558
- Testing EN-12266, ISO 5208
- Design EN-12516, ISO 17292

Official approvals

- CERTIFICATE FIRE SAFE
- TA-LUFT VDI 2440
- ISO 15848-1
- ATEX 2014/34/EU
- PED 2014/68/EU
- SIL 3 CAPABLE
- EN 161/EN ISO 23553-1

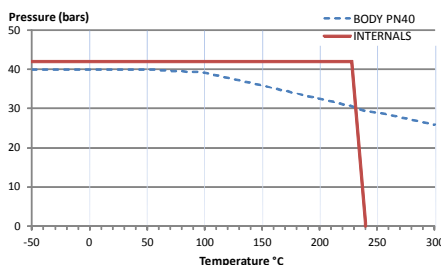

PEKOS GROUP CERTIFICATES:

ISO 9001: 2015 / 2014/68/EU /API-6D

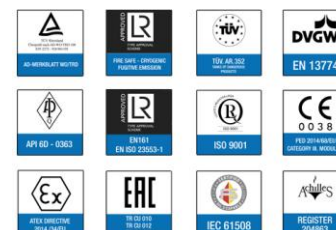

DIMENSIONS & Technical information

DN	PN	D	L	E	A	B	C	F	H	G	V	X	Y	Z	n x d	ISO 5211	Torque	MAST	Weight
15	40	15	130	95	45	65	16	52	185	100	14	11	11	13,5	4 x 14	F05	12	45	3
20	40	20	150	105	58	75	18	54	185	102	14	11	11	13,5	4 x 14	F05	14	45	4
25	40	25	160	115	68	85	18	60	185	110	18	14	17	19,5	4 x 14	F05	17	99	5
32	40	32	180	140	78	100	18	65	185	115	18	14	17	19,5	4 x 18	F05	30	99	7
40	40	40	200	150	88	110	18	75	293	129	22	17	20	30	4 x 18	F07	40	261	9
50	40	50	230	165	102	125	20	83	293	137	22	17	20	30	4 x 18	F07	65	261	13
65	40	65	290	185	122	145	22	96	293	150	22	17	20	30	8 x 18	F07	85	261	20
80	40	80	310	200	138	160	24	114	450	187	28	22	22	40	8 x 18	F10	130	545	26
100	40	100	350	235	162	190	24	128	450	201	28	22	22	40	8 x 22	F10	190	545	36
125	40	125	400	270	188	220	26	158	740	247	36	27	35	50	8 x 26	F12	350	1119	73

\*\* Depending on service conditions.

\* Dimensions are in mm.

\* Torque & MAST are in Nm.

\* Weight is in Kilograms

\* Torque values have been measured ΔP at maximum rating at room temperature