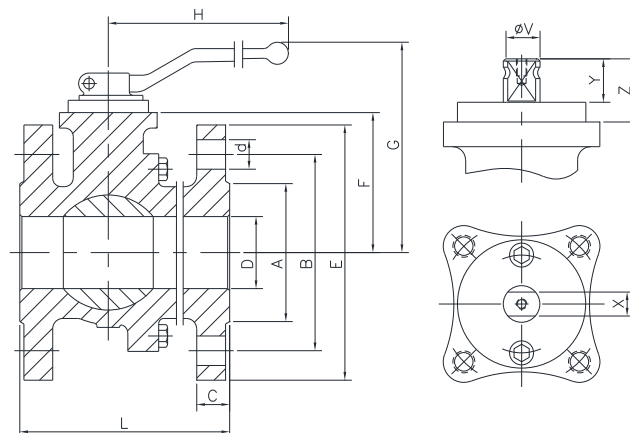
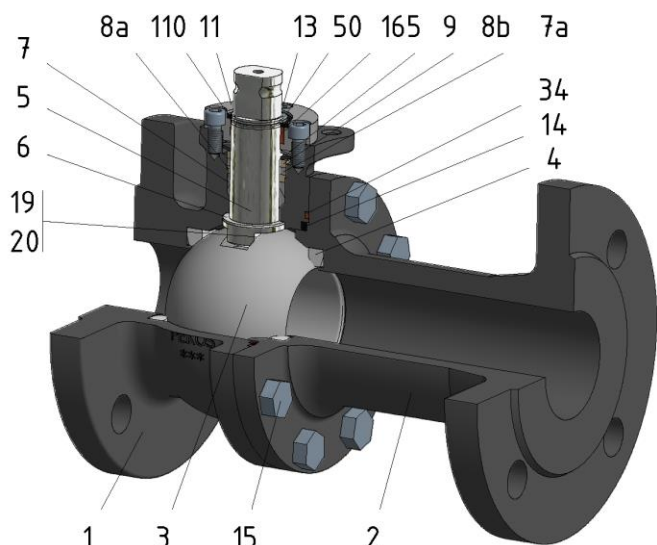

FIG.Z 29 SSSG PN40 DN15/125 F1



Position	Description	Material
01	Body 1	C.S. 1.6220
02	Body 2	C.S. 1.6220
03	Ball	S.S. 1.4408
04	Seat	PTFE (modified)+CG
05	Stem	S.S. 1.4401
06	Stem seal	PTFE (modified)+CG
07	Stem packing	PTFE (modified)+CG
07a	Stem packing 2	Graphite
08a	Gland packing 1	S.S. 1.4401
08b	Gland packing 2	S.S. 1.4401
09	Spring washer	S.S. 1.4310
11	Cover	S.S. 1.4408
13	Cover bolt	A4-70
14	Body seal 1	PTFE (modified)+CG
15	Body bolt	A2-70
16	Handle	WCB
17	Handle bolt	1.045(8.8)
19	Spring	S.S. 1.4401
20	Antistatic ball	S.S. 1.4401
34	Body seal 2	Graphite
50	Subjection ring	S.S. 1.4021
110	Subjection ring seal	S.S. 1.4401 Nitrided
165	Stem bearing	PTFE (modified)+FG

General features

- Floating ball.
- Split body.
- Full bore.
- Soft seat.
- Bidirectional.
- Anti Blow out proof stem.
- Autoadjustable packing.
- Anti static device.
- Self-cavity pressure relief.

Standards

- Top flange ISO 5211
- Flanges EN 1092-01
- Face to face EN 558
- Testing EN-12266, ISO 5208
- Design EN-12516, ISO 17292

Official approvals

- CERTIFICATE FIRE SAFE
- TA-LUFT VDI 2440
- ISO 15848-1
- ATEX 2014/34/EU
- PED 2014/68/EU
- SIL 3 CAPABLE
- EN 161/EN ISO 23553-1

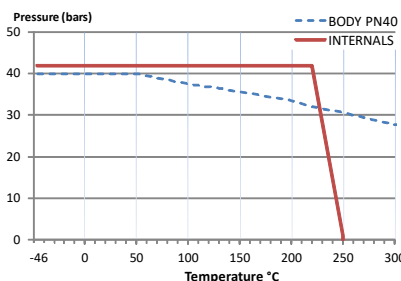

PEKOS GROUP CERTIFICATES:

ISO 9001: 2015 / 2014/68/EU / API-6D



DIMENSIONS & Technical information

DN	PN	D	L	E	A	B	C	F	H	G	V	X	Y	Z	n x d	ISO 5211	Torque	MAST	Weight
15	40	15	130	95	45	65	16	51	185	108	14	11	11	13,5	4 x 14	F05	14	44	3
20	40	20	150	105	58	75	18	53	185	109	14	11	11	13,5	4 x 14	F05	17	44	4
25	40	25	160	115	68	85	18	59	185	116	18	14	17	19,5	4 x 14	F05	22	95	5
32	40	32	180	140	78	100	18	64	185	119	18	14	17	19,5	4 x 18	F05	36	95	7
40	40	40	200	150	88	110	18	75	293	145	22	17	20	30	4 x 18	F07	48	250	9
50	40	50	230	165	102	125	20	83	293	153	22	17	20	30	4 x 18	F07	78	250	13
65	40	65	290	185	122	145	22	96	293	166	22	17	20	30	8 x 18	F07	102	250	20
80	40	80	310	200	138	160	24	113	450	208	28	22	22	40	8 x 18	F10	156	523	26
100	40	100	350	235	162	190	24	128	450	222	28	22	22	40	8 x 22	F10	228	523	36
125	40	125	400	270	188	220	26	157	740	247	36	27	35	50	8 x 26	F12	420	1073	73

** Depending on service conditions. * Dimensions are in mm. * Torque & MAST are in Nm. * Weight is in Kilograms

* Torque values have been measured ΔP at maximum rating at room temperature