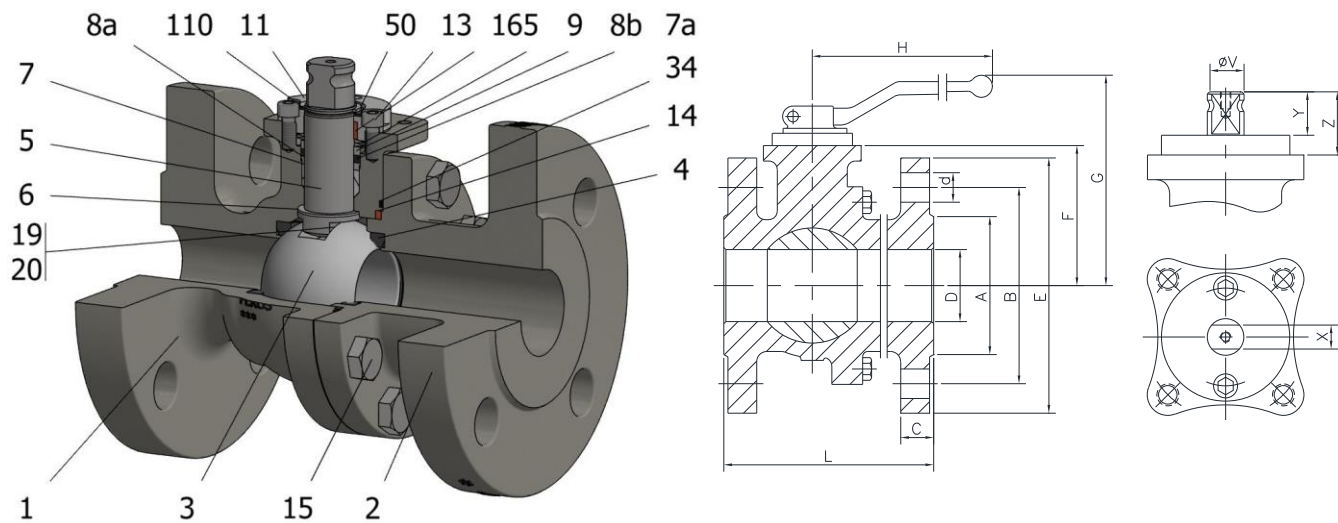

FIG.Z 29 SSSG PN63/100 DN15-40 F1



Position	Description	Material
01	Body 1	C.S. 1.6220
02	Body 2	C.S. 1.6220
03	Ball	S.S. 1.4408
04	Seat	PTFE (modified)+CG
05	Stem	XM-19
06	Stem seal	PTFE (modified)+CG
07	Stem packing	PTFE (modified)+CG
07a	Stem packing 2	Graphite
08a	Gland packing 1	S.S. 1.4401
08b	Gland packing 2	S.S. 1.4401
09	Spring washer	S.S. 1.4310
11	Cover	S.S. 1.4408
13	Cover bolt	A4-70
14	Body seal 1	PTFE (modified)+CG
15	Body bolt	A4-70
16	Handle	WCB
17	Handle bolt	1.045(8.8)
19	Spring	S.S. 1.4401
20	Antistatic ball	S.S. 1.4401
34	Body seal 2	Graphite
50	Subjection ring	S.S. 1.4021
110	Subjection ring seal	S.S. 1.4401 Nitrided
165	Stem bearing	PTFE (modified)+FG

**General features**

- Floating ball.
- Split body.
- Full bore.
- Soft seat.
- Bidirectional.
- Anti Blow out proof stem.
- Autoadjustable packing.
- Anti static device.
- Self-cavity pressure relief.

**Standards**

- Top flange ISO 5211
- Flanges EN 1092-01
- Face to face EN 558
- Testing EN-12266, ISO 5208
- Design EN-12516, ISO 17292

**Official approvals**

- CERTIFICATE FIRE SAFE
- TA-LUFT VDI 2440
- ISO 15848-1
- ATEX 2014/34/EU
- PED 2014/68/EU
- SIL 3 CAPABLE

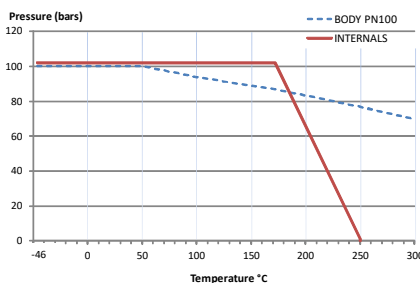

**PEKOS GROUP CERTIFICATES:**

ISO 9001: 2015 / 2014/68/EU / API-6D



**DIMENSIONS & Technical information**

DN	PN	D	L	E	A	B	C	F	H	G	V	X	Y	Z	n x d	ISO 5211	Torque	MAST	Weight
15	100	15	130	105	45	75	20	52	185	100	14	11	11	13,5	4 x 14	F05	19	81	9
20	100	20	150	130	57	90	22	54	185	102	14	11	11	13,5	4 x 18	F05	22	81	10
25	100	25	160	140	68	100	24	60	185	110	18	14	17	19,5	4 x 18	F05	48	175	12
32	100	32	180	155	77	110	24	65	185	115	18	14	17	19,5	4 x 22	F05	73	175	16
40	100	40	200	170	88	125	26	75	293	129	22	17	20	30	4 x 22	F07	108	464	20

\*\* Depending on service conditions.

\* Dimensions are in mm.

\* Torque & MAST are in Nm.

\* Weight is in Kilograms

\* Torque values have been measured  $\Delta P$  at maximum rating at room temperature