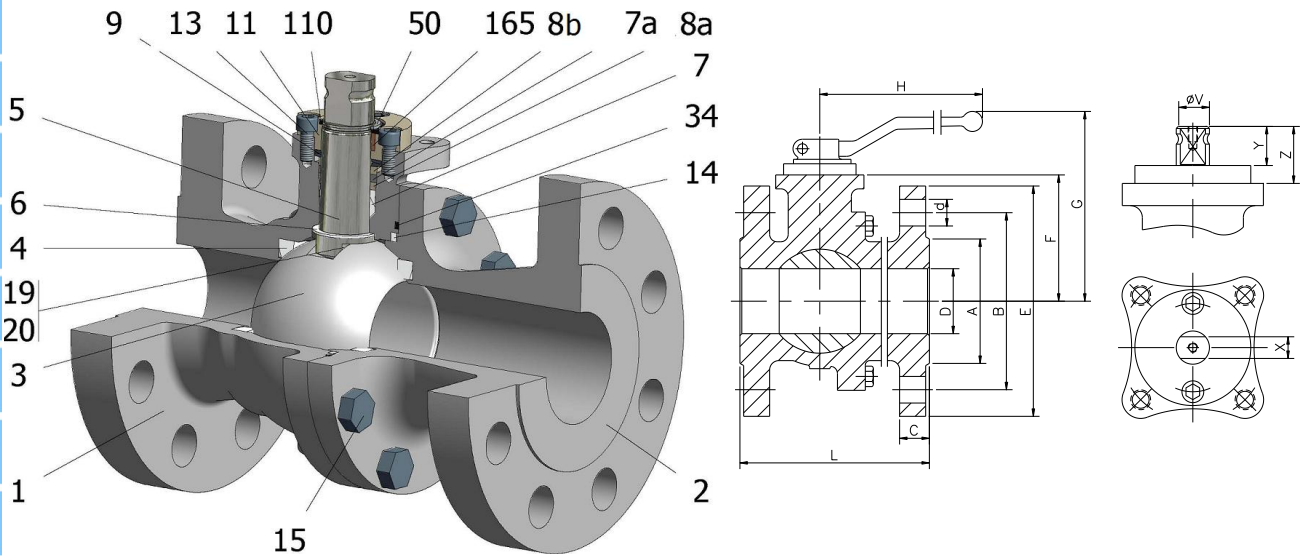

FIG.Z 36 PGGG CL300 1/2"-2 1/2"



Position	Description	Material
01	Body 1	S.S. A351 CF8M
02	Body 2	S.S. A351 CF8M
03	Ball	S.S. A351 CF8M
04	Seat	PEEK
05	Stem	S.S. AISI 316
06	Stem seal	PEEK
07	Stem packing 1	Graphite
07a	Stem packing 2	Graphite
08	Gland packing	S.S. AISI 316
08a	Gland packing 1	S.S. AISI 316
09	Spring washer	S.S. AISI 301
11	Cover	S.S. A351 CF8M
13	Cover bolt	S.S. (316)
14	Body seal 1	Graphite
15	Body bolt	A193 B8M
16	Handle	WCB/A351 CF8M
17	Handle bolt	S.S. (304)/1.045(8.8)
19	Spring	S.S. AISI 316
20	Antistatic ball	S.S. AISI 316
34	Body seal 2	Graphite
50	Subjection ring	S.S. AISI 420
110	Subjection ring seal	S.S. AISI 316 Nitrided
165	Stem bearing	Carbongraphite

General features

- Floating ball.
- Split body.
- Full bore.
- Soft seat.
- Bidirectional.
- Anti Blow out proof stem.
- Autoadjustable packing.
- Anti static device.
- Self-cavity pressure relief.

Standards

- Top flange ISO 5211
- Flanges ANSI B16.5
- Face to face ANSI B16.10
- Testing API 598, API 6D, BS 6755-1
- Design API 6D, B16.34
- Materials according to NACE MR0175

Official approvals

- TA-LUFT VDI 2440
- ISO 15848-1
- API 6D.
- ATEX 2014/34/EU
- PED 2014/68/EU
- SIL 3 CAPABLE
- EN 161/EN ISO 23553-1
- CERTIFICATE FIRE SAFE

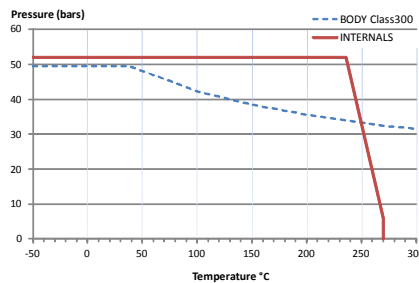

PEKOS GROUP CERTIFICATES:

ISO 9001: 2015 / 2014/68/EU /API-6D



DIMENSIONS & Technical information

DN	CL	D	L	E	A	B	C	F	H	G	V	X	Y	Z	n x d	ISO 5211	Torque	MAST	Weight
1/2"	300	15	140	95	35	67	14	52	185	103	14	11	11	13,5	4 x 16	F05	22	42	3
3/4"	300	20	152	115	43	83	16	54	185	105	14	11	11	13,5	4 x 19	F05	26	42	4
1"	300	25	165	125	51	89	18	60	185	111	18	14	17	19,5	4 x 19	F05	30	92	5
1 1/2"	300	40	190	155	73	114	22	75	293	129	22	17	20	30	4 x 22	F07	67	244	10
2"	300	50	216	165	92	127	24	84	293	138	22	17	20	30	8 x 19	F07	112	244	12
2 1/2"	300	65	241	190	105	149	27	96	293	150	22	17	20	30	8 x 22	F07	144	244	19

** Depending on service conditions.

* Dimensions are in mm.

* Torque & MAST are in Nm

* Weight is in Kilograms

* Torque values have been measured ΔP at maximum rating at room temperature