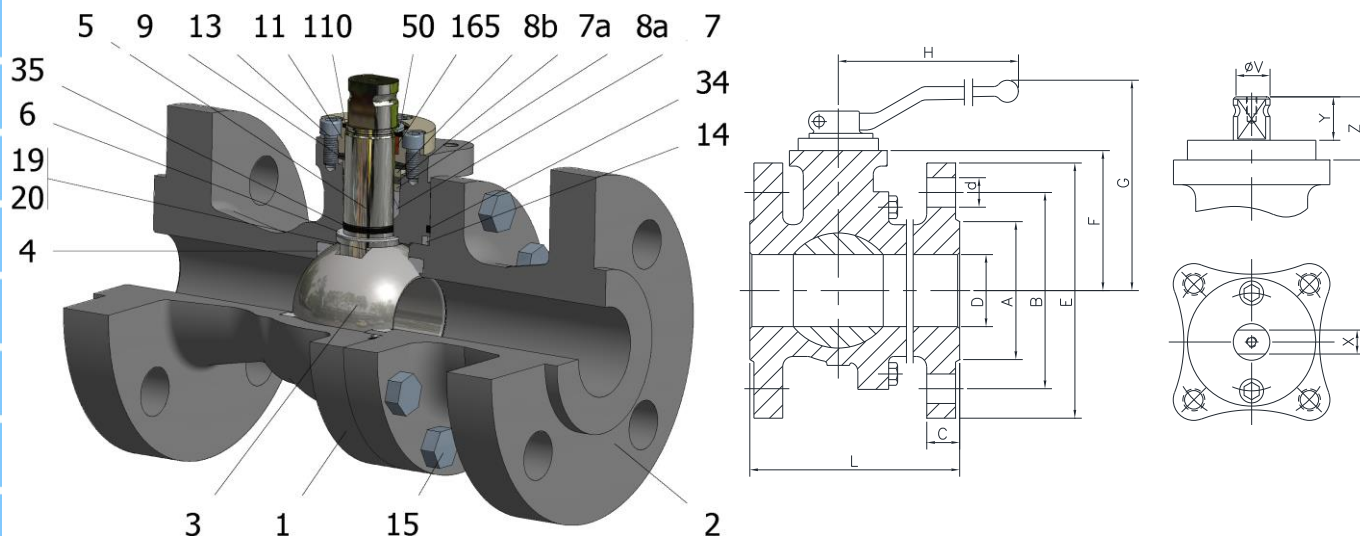

FIG.Z 66 SSSGV CL600 1/2"-2"



Position	Description	Material
01	Body 1	S.S. A351 CF8M
02	Body 2	S.S. A351 CF8M
03	Ball	S.S. A351 CF8M
04	Seat	PTFE (modified)+CG
05	Stem	XM-19
06	Stem seal	PTFE (modified)+CG
07	Stem packing 1	PTFE (modified)+CG
07a	Stem packing 2	Graphite
08	Gland packing	S.S. AISI 316
08a	Gland packing 1	S.S. AISI 316
09	Spring washer	S.S. AISI 301
11	Cover	S.S. AISI 316
13	Cover bolt	S.S. (316)
14	Body seal 1	PTFE (modified)+CG
15	Body bolt	A193 B8M
16	Handle	WCB
17	Handle bolt	1.045(8.8)
19	Spring	S.S. AISI 316
20	Antistatic ball	S.S. AISI 316
34	Body seal 2	Graphite
35	O ring stem	FKM
50	Subjection ring	S.S. AISI 420
110	Subjection ring seal	S.S. AISI 316 Nitrided
165	Stem bearing	PTFE (modified)+FG

General features

- Floating ball.
- Split body.
- Full bore.
- Soft seat.
- Bidirectional.
- Anti Blow out proof stem.
- Autoadjustable packing.
- Anti static device.
- Self-cavity pressure relief.

Standards

- Top flange ISO 5211
- Flanges ANSI B16.5
- Face to face ANSI B16.10
- Testing API 598, API 6D, BS 6755-1
- Design API 6D, B16.34
- Materials according to NACE MR0175

Official approvals

- CERTIFICATE FIRE SAFE
- TA-LUFT VDI 2440
- ISO 15848-1
- ATEX 2014/34/EU
- API 6D.
- PED 2014/68/EU
- SIL 3 CAPABLE
- EN 161/EN ISO 23553-1

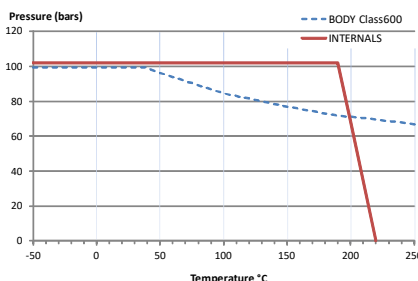

PEKOS GROUP CERTIFICATES:
ISO 9001: 2015 / 2014/68/EU / API-6D



DIMENSIONS & Technical information

DN	CL	D	L	E	A	B	C	F	H	G	V	X	Y	Z	n x d	ISO 5211	Torque	MAST	Weight
1/2"	600	15	165	95	35	67	22	51	185	108	14	11	11	13,5	4 x 16	F05	19	81	8
3/4"	600	20	190	115	43	83	24	53	185	110	14	11	11	13,5	4 x 19	F05	22	81	8
1"	600	25	216	125	51	89	25	59	185	116	18	14	17	19,5	4 x 19	F05	48	175	9
1 1/2"	600	40	241	155	73	114	30	75	293	145	22	17	20	30	4 x 22	F07	108	464	14
2"	600	50	292	165	92	127	32	83	293	153	22	17	20	30	8 x 19	F07	187	464	19

** Depending on service conditions.

* Dimensions are in mm. * Torque & MAST are in Nm * Weight is in Kilograms

* Torque values have been measured ΔP at maximum rating at room temperature