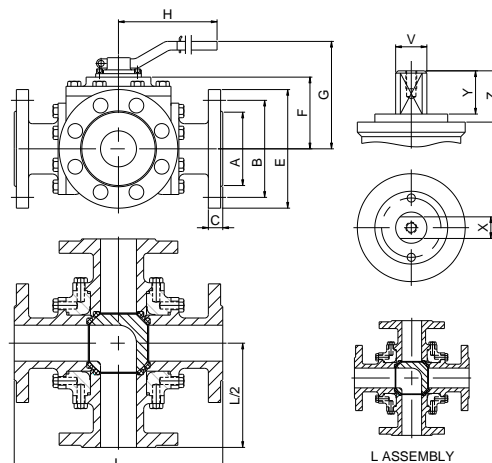
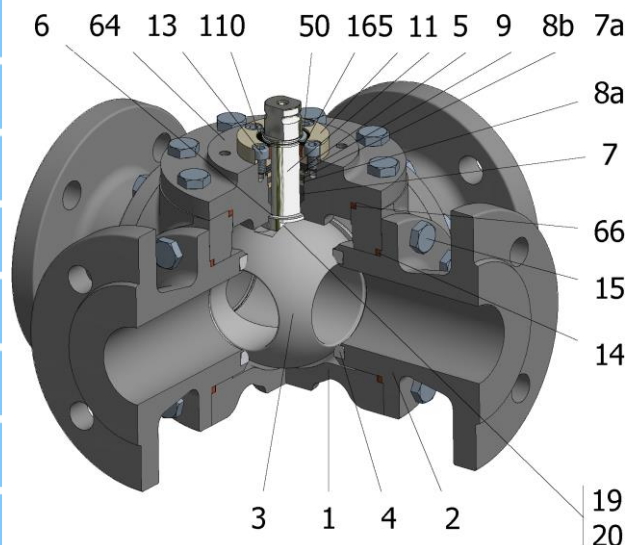

FIG.Z 76 TTT PN40 DN25/100 L



Position	Description	Material
01	Body 1	S.S. 1.4408
02	Body 2	S.S. 1.4408
03	Ball	S.S. 1.4408
04	Seat	PTFE (modified)
05	Stem	S.S. 1.4401
06	Stem seal	PTFE (modified)+FG
07	Stem packing	PTFE (modified)
07a	Stem packing 2	Graphite
08a	Gland packing 1	S.S. 1.4401
08b	Gland packing 2	S.S. 1.4401
09	Spring washer	S.S. 1.4310
11	Cover	S.S. 1.4408
13	Cover bolt	A4-70
14	Body seal 1	PTFE (modified)
15	Body bolt	A4-70
16	Handle	WCB
17	Handle bolt	1.045(8.8)
19	Spring	S.S. 1.4401
20	Antistatic ball	S.S. 1.4401
23	Handle pin	S.S. 1.4021
24	Lengthening handle	S.S. 1.0254
64	Body cover	S.S. 1.4408
66	Body cover seal	PTFE (modified)
50	Subjection ring	S.S. 1.4021
110	Subjection ring seal	S.S. 1.4401 Nitrided
165	Stem bearing	PTFE (modified)+FG

General features

- Floating ball.
- Split body.
- Full bore.
- Soft seat.
- Four way
- Anti Blow out proof stem.
- Autoadjustable packing.
- Anti static device.
- Self-cavity pressure relief.

Standards

- Top flange ISO 5211
- Flanges EN 1092-01
- Testing EN-12266, ISO 5208
- Design EN-12516, ISO 17292

Official approvals

- TA-LUFT VDI 2440
- ISO 15848-1
- ATEX 2014/34/EU
- PED 2014/68/EU
- SIL 3 CAPABLE

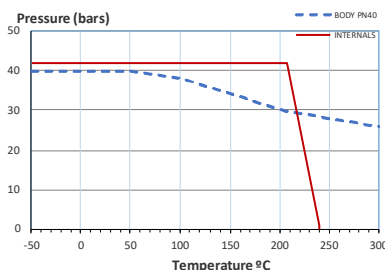

PEKOS GROUP CERTIFICATES:

ISO 9001: 2015 / 2014/68/EU /API-6D



DIMENSIONS & Technical information

DN	PN	D	L	E	A	B	C	F	H	G	V	X	Y	Z	n x d	ISO 5211	Torque	MAST	Weight
25	40	25	230	115	68	85	18	67	185	117	18	14	17	19,5	4 x 14	F05	27	95	15
40	40	40	260	150	88	110	18	82	293	136	22	17	20	30	4 x 18	F07	60	250	24
50	40	50	290	165	102	125	20	90	293	144	22	17	20	30	4 x 18	F07	97	250	33
65	40	65	340	185	122	145	22	109	450	182	28	22	22	40	8 x 18	F10	127	523	52
80	40	80	380	200	138	160	24	132	740	205	36	27	35	50	8 x 18	F12	195	1073	66
100	40	100	430	235	162	190	24	147	740	220	36	27	35	50	8 x 22	F12	285	1073	99

** Depending on service conditions.

* Dimensions are in mm.

* Torque & MAST are in Nm.

* Weight is in Kilograms

* Torque values have been measured ΔP at maximum rating at room temperature