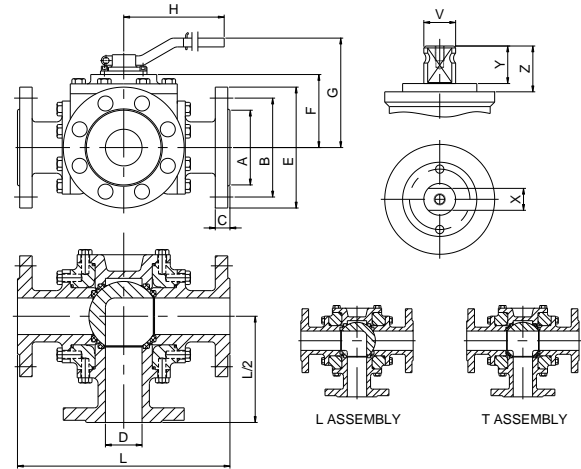
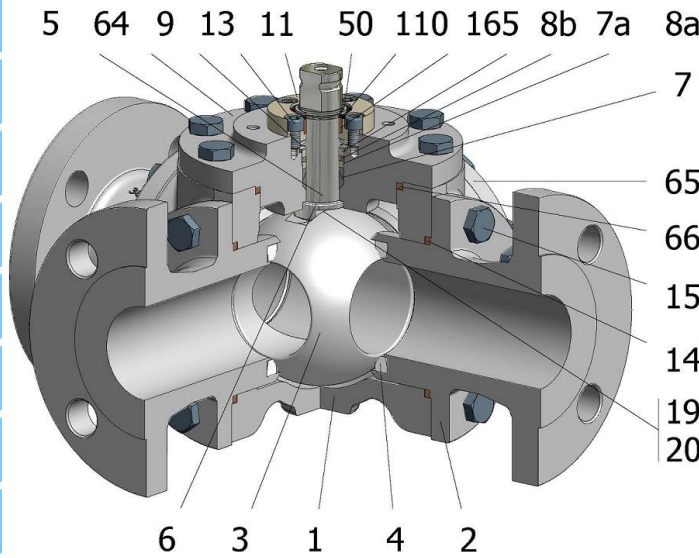

FIG.Z 84 SSG CL150 1"-8" L/T



Position	Description	Material
01	Body 1	C.S. A216 WCC
02	Body 2	C.S. A216 WCC
03	Ball	S.S. A351 CF8M
04	Seat	PTFE (modified)+CG
05	Stem	S.S. AISI 316
06	Stem seal	PTFE (modified)+CG
07	Stem packing 1	PTFE (modified)+CG
07a	Stem packing 2	Graphite
08	Gland packing	S.S. AISI 316
08a	Gland packing 1	S.S. AISI 316
09	Spring washer	S.S. AISI 301
11	Cover	S.S. A351 CF8M
13	Cover bolt	S.S. (316)
14	Body seal 1	Graphite
15	Body bolt	A193 B7M
16	Handle	WCB
17	Handle bolt	1.045(8.8)
19	Spring	S.S. AISI 316
20	Antistatic ball	S.S. AISI 316
50	Subjection ring	S.S. AISI 304
64	Body cover	C.S. A216 WCC
65	Body blind	C.S. A216 WCC
66	Body cover seal	Graphite
110	Subjection ring seal	S.S. AISI 316 Nitrided
165	Stem bearing	PTFE (modified)+FG

General features

- Floating ball.
- Split body.
- Full bore.
- Soft seat.
- Three way
- Fire Safe Design
- Anti Blow out proof stem.
- Autoadjustable packing.
- Anti static device.
- Self-cavity pressure relief.

Standards

- Top flange ISO 5211
- Flanges ANSI B16.5
- Testing API 598, API 6D, BS 6755-1
- Design API 6D, B16.34
- Materials according to NACE MR0175

Official approvals

- TA-LUFT VDI 2440
- ISO 15848-1
- API 6D.
- ATEX 2014/34/EU
- PED 2014/68/EU
- SIL 3 CAPABLE

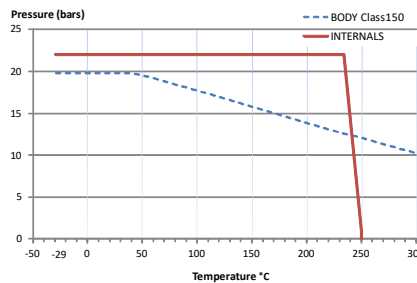

PEKOS GROUP CERTIFICATES:

ISO 9001: 2015 / 2014/68/EU / API-6D



DIMENSIONS & Technical information

DN	CL	D	L	E	A	B	C	F	H	G	V	X	Y	Z	n x d	ISO 5211	Torque	MAST	Weight
1"	150	25	230	110	51	79	14	67	185	115	18	14	17	19,5	4 x 16	F05	29	92	12
1 1/2"	150	40	260	125	73	98	16	82	293	136	22	17	20	30	4 x 16	F07	58	244	24
2"	150	50	290	150	92	121	17	90	293	144	22	17	20	30	4 x 19	F07	86	244	29
2 1/2"	150	65	340	180	105	140	19	109	450	182	28	22	22	40	4 x 19	F10	112	510	47
3"	150	80	380	190	127	152	21	132	740	229	36	27	35	50	4 x 19	F12	185	1047	70
4"	150	100	430	230	157	191	25	147	740	241	36	27	35	50	8 x 19	F12	260	1047	102
6"	150	150	490	280	216	241	27	216	750	310	48	36	40	63	8 x 22	F14	720	2482	178
8"	150	201	600	345	270	298	30	258	750	352	48	36	40	63	8 x 22	F14	1296	2482	301

** Depending on service conditions.

* Dimensions are in mm.

* Torque & MAST are in Nm

* Weight is in Kilograms

* Torque values have been measured ΔP at maximum rating at room temperature