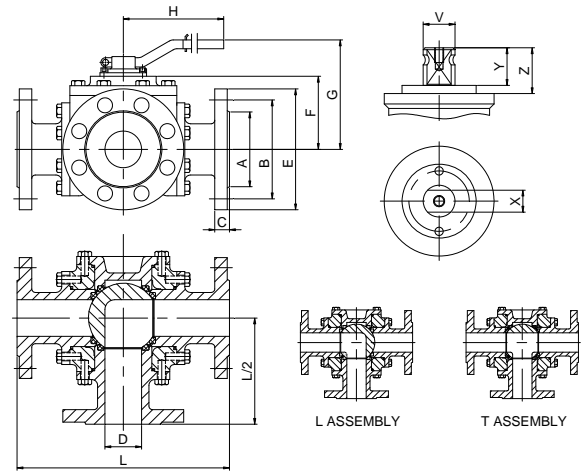
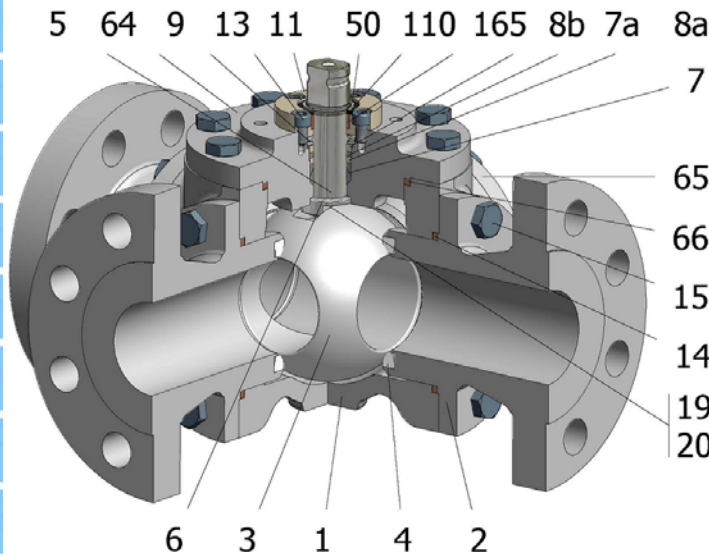

FIG.Z 86 SSS CL300 1"-4" L/T



Position	Description	Material
01	Body 1	S.S. A351 CF8M
02	Body 2	S.S. A351 CF8M
03	Ball	S.S. A351 CF8M
04	Seat	PTFE (modified)+CG
05	Stem	S.S. AISI 316
06	Stem seal	PTFE (modified)+CG
07	Stem packing 1	PTFE (modified)+CG
07a	Stem packing 2	Graphite
08a	Gland packing 1	S.S. AISI 316
08b	Gland packing 2	S.S. AISI 316
09	Spring washer	S.S. AISI 301
11	Cover	S.S. A351 CF8M
13	Cover bolt	S.S. (316)
14	Body seal 1	PTFE (modified)+CG
15	Body bolt	A193 B8M
16	Handle	WCB
17	Handle bolt	1.045(8.8)
19	Spring	S.S. AISI 316
20	Antistatic ball	S.S. AISI 316
50	Subjection ring	S.S. AISI 304
64	Body cover	S.S. A351 CF8M
65	Body blind	S.S. A351 CF8M
66	Body cover seal	PTFE (modified)+CG
110	Subjection ring seal	S.S. AISI 316 Nitrided
165	Stem bearing	PTFE (modified)+FG

General features

- Floating ball.
- Split body.
- Full bore.
- Soft seat.
- Three way
- Anti Blow out proof stem.
- Autoadjustable packing.
- Anti static device.
- Self-cavity pressure relief.

Standards

- Top flange ISO 5211
- Flanges ANSI B16.5
- Testing API 598, API 6D, BS 6755-1
- Design API 6D, B16.34
- Materials according to NACE MR0175

Official approvals

- TA-LUFT VDI 2440
- ISO 15848-1
- ATEX 2014/34/EU
- API 6D.
- PED 2014/68/EU
- SIL 3 CAPABLE

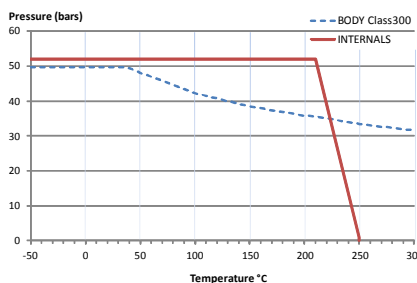

PEKOS GROUP CERTIFICATES:



DIMENSIONS & Technical information

DN	CL	D	L	E	A	B	C	F	H	G	V	X	Y	Z	n x d	ISO 5211	Torque	MAST	Weight
1"	300	25	230	125	51	89	18	67	185	115	18	14	17	19,5	4 x 19	F05	34	92,2	13
1 1/2"	300	40	260	155	73	114	21	82	293	136	22	17	20	30	4 x 22	F07	76	244,3	25
2"	300	50	290	165	92	127	22	90	293	144	22	17	20	30	8 x 19	F07	126	244,3	31
2 1/2"	300	65	340	190	105	149	26	109	450	182	28	22	22	40	8 x 22	F10	162	509,7	50
3"	300	80	380	210	127	168	29	132	740	229	36	27	35	50	8 x 22	F12	270	1047,2	75
4"	300	100	430	255	157	200	32	147	740	241	36	27	35	50	8 x 22	F12	389	1047,2	112

** Depending on service conditions.

* Dimensions are in mm.

* Torque & MAST are in Nm

* Weight is in Kilogram

* Torque values have been measured ΔP at maximum rating at room temperature