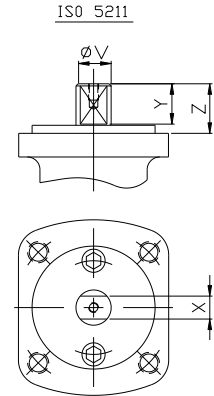
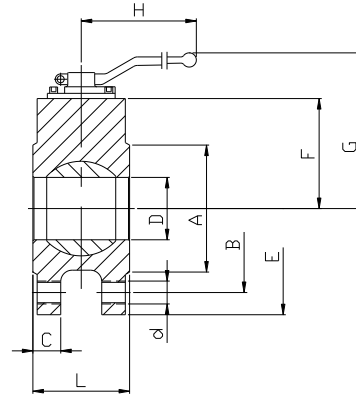
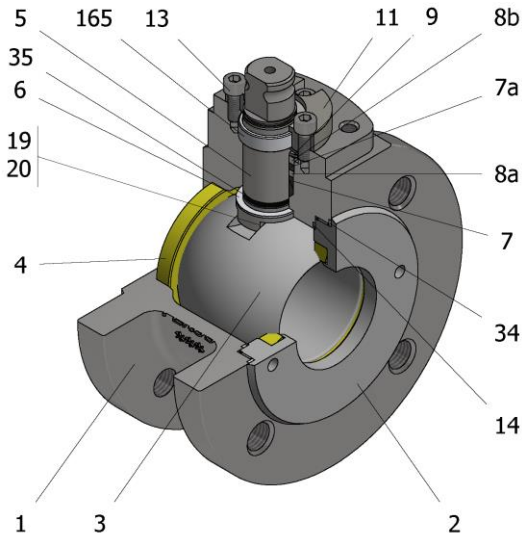

FIG.Z 96 TTTGV CL150 3/4"-4"



Position	Description	Material
01	Body 1	S.S. A351 CF8M
02	Body 2	S.S. AISI 316
03	Ball	S.S. A351 CF8M
04	Seat	PTFE (modified)
05	Stem	S.S. AISI 316
06	Stem seal	PTFE (modified)+FG
07	Stem packing	PTFE (modified)
07a	Stem packing 2	Graphite
08a	Gland packing 1	S.S. AISI 316
08b	Gland packing 2	S.S. AISI 316
09	Spring washer	S.S. AISI 301
11	Cover	S.S. A351 CF8M
13	Cover bolt	S.S. (316)
14	Body seal 1	PTFE (modified)
16	Handle	A351 CF8M/WCB
17	Handle bolt	S.S. (304)/1.045(8.8)
19	Spring washer	S.S. AISI 316
20	Antistatic ball	S.S. AISI 316
34	Body seal 2	Graphite
35	O ring stem	FKM
50	Subjection ring	S.S. AISI 420
165	Stem bearing	PTFE (modified)+FG

General features

- Floating ball.
- End entry.
- Full bore.
- Soft seat.
- Bidirectional.
- Anti Blow out proof stem.
- Autoadjustable packing.
- Anti static device.
- Self-cavity pressure relief.
- Short measure

Standards

- Top flange ISO 5211
- Flanges ANSI B16.5
- Design B16.34
- Testing API 598, BS 6755-1
- Materials according to NACE MR0175
- Face to face EN 558 serie 100

Official approvals

- CERTIFICATE FIRE SAFE
- TA-LUFT VDI 2440
- ISO 15848-1
- ATEX 2014/34/EU
- PED 2014/68/EU
- SIL 3 CAPABLE

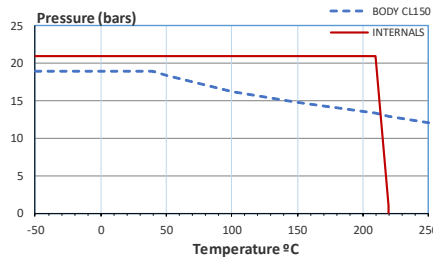

PEKOS GROUP CERTIFICATES:

ISO 9001: 2015 / 2014/68/EU /API-6D



DIMENSIONS & Technical information

DN	CL	D	L	E	A	B	C	F	H	G	V	X	Y	Z	n x d	ISO 5211	Torque	MAST	Weight
3/4"	150	20	39	105	43	70	-	52	185	117	14	11	11	12,6	4 x W 1/2"	F03	11	42	2
1"	150	25	44	110	51	79	10	55	185	120	14	11	11	13,5	4 x W 1/2"	F05/1	16	42	3
1 1/2"	150	40	64	125	65	98	13	75	185	129	22	17	20	30	4 x W 1/2"	F07	32	244	6
2"	150	50	83	150	92	121	15	83	293	137	22	17	20	30	4 x W 5/8"	F07	48	244	7
2 1/2"	150	65	105	180	105	140	16	92	293	150	22	17	20	30	4 x W 5/8"	F07	62	244	10
3"	150	75	120	190	127	152	18	110	450	185	28	22	22	40	4 x W 5/8"	F10	103	510	14
4"	150	98	152	230	157	190	23	126	450	199	28	22	22	40	8 x W 5/8"	F10	145	510	22

** Depending on service conditions.

* Dimensions are in mm.

* Torque & MAST are in Nm

* Weight is in Kilograms

* Torque values have been measured ΔP at maximum rating at room temperature