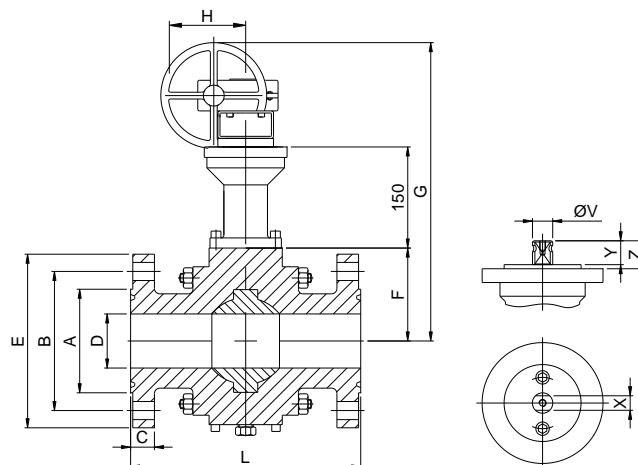
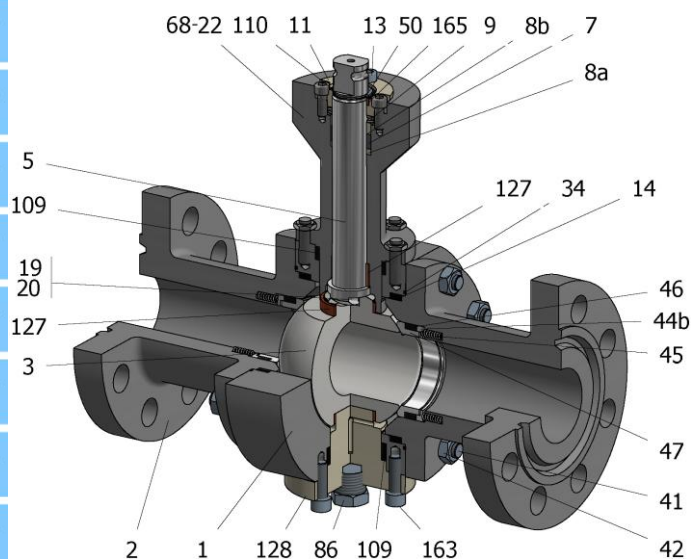

FIG.ZFGKMS 154 CGGG CL900/1500 2"- 2 1/2" RTJ



Position	Description	Material
01	Body 1	C.S. A-105
02	Body 2	C.S. A-105
03	Ball	XM-19+Cr-Carbide
05	Stem	XM-19
07	Stem packing 1	Graphite
08a	Gland packing 1	S.S. AISI 316
08a	Gland packing 2	S.S. AISI 316
09	Spring washer	Inconel X718
11	Cover	C.S. A-105
13	Cover bolt	S.S. (316)
14	Body seal 1	Graphite
19	Spring	S.S. AISI 316
20	Antistatic ball	S.S. AISI 316
22	Stop pin	S.S. AISI 316
34	Body seal 2	Graphite
41	Stud	A320 L7M
42	Nut	A194 7M
44b	Ring seat 2	S.S. AISI 316
45	Spring seat	Inconel X750
46	Seat seal	Graphite
47	Metal seat	XM-19+Cr-Carbide
50	Subjection ring	S.S. AISI 420
68	Stem extension casing	C.S. A-105
86	Drain plug	C.S. A350 LF2
86a	Vent plug	C.S. A350 LF2
109	Cover seal	Graphite
110	Subjection ring seal	S.S. AISI 316 Nitrided
127	Stem bearing	Carbongraphite
128	Body cover 2	C.S. A-105
163	Body cover 2 bolt	S.S. (316)
165	Stem bearing	Carbongraphite

General features

- Full trunnion.
- Three pieces.
- Full bore.
- Metal to Metal.
- Bidirectional.
- Spring loaded seat system.
- Anti Blow out proof stem.
- Autoadjustable packing.
- Anti static device.
- Self-cavity pressure relief.
- Double Block and Bleed.
- Security stem extension
- TA-LUFT.

Standards

- Top flange ISO 5211
- Flanges ANSI B16.5
- Face to face ANSI B16.10
- Design API 6D, B16.34
- Testing API 598, API 6D, BS 6755-1
- Materials according to NACE MR0175

Official approvals

- CERTIFICATE FIRE SAFE
- API 6D.
- ATEX 2014/34/EU
- PED 2014/68/EU
- SIL 3 CAPABLE

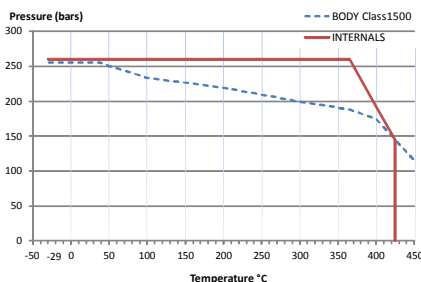

PEKOS GROUP CERTIFICATES:



DIMENSIONS & Technical information

DN	CL	D	L	E	A	B	C	F	H	G	V	X	Y	Z	n x d	ISO 5211	Torque	MAST	Weight
2"	1500	50	371	215	124	165	47	238	200	535	28	22	22	40	8 x 25	F10	560	968	51
2 1/2"	1500	65	422	245	137	191	50	245	200	543	28	22	22	36	8 x 29	F12-1	1080	968	85

** Depending on service conditions.

* Dimensions are in mm. * Torque & MAST are in Nm * Weight is in Kilograms

* Torque values have been measured ΔP at maximum rating at room temperature