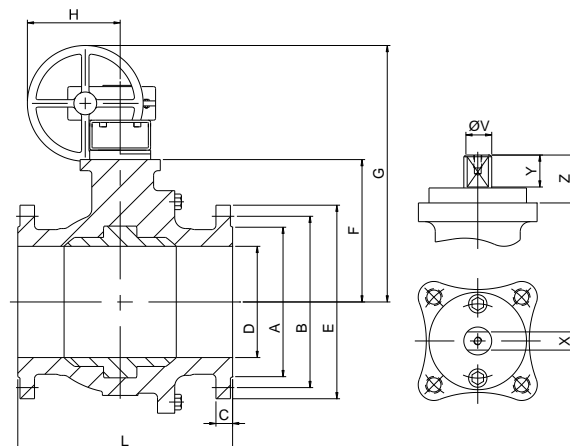
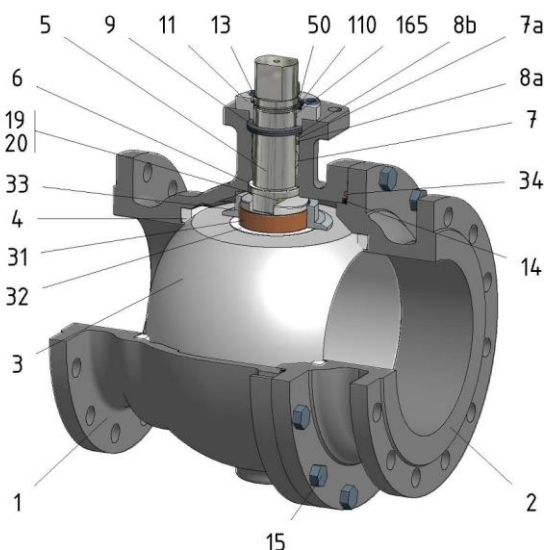

FIG.ZG 06 TTTG PN16 DN250-300 F5



Position	Description	Material
01	Body 1	S.S. 1.4408
02	Body 2	S.S. 1.4408
03	Ball	S.S. 1.4408
04	Seat	PTFE (modified)
05	Stem	S.S. 1.4401
06	Stem seal	PTFE (modified)+FG
07	Stem packing	PTFE (modified)
07a	Stem packing 2	Graphite
08a	Gland packing 1	S.S. 1.4401
08b	Gland packing 2	S.S. 1.4401
09	Spring washer	S.S. 1.4310
11	Cover	S.S. 1.4408
13	Cover bolt	A4-70
14	Body seal 1	PTFE (modified)
15	Body bolt	A4-70
19	Spring	S.S. 1.4401
20	Antistatic ball	S.S. 1.4401
31	Bearing	PTFE (modified)
32	Bearing disk	PTFE (modified)+FG
33	Support bearing	S.S. 1.4401
34	Body seal 2	Graphite
50	Subjection ring	S.S. 1.4021
110	Subjection ring seal	S.S. 1.4401 Nitrided
165	Stem bearing	PTFE (modified)+FG

General features

- Guided ball.
- Split body.
- Full bore.
- Soft seat.
- Bidirectional.
- Anti Blow out proof stem.
- Autoadjustable packing.
- Anti static device.
- Self-cavity pressure relief.

Standards

- Top flange ISO 5211
- Flanges EN 1092-01
- Face to face EN 558
- Testing EN-12266, ISO 5208
- Design EN-12516, ISO 17292

Official approvals

- CERTIFICATE FIRE SAFE
- TÜV.AD-MERKBLATT A4
- TA-LUFT VDI 2440
- ISO 15848-1
- ATEX 2014/34/EU
- PED 2014/68/EU
- SIL 3 CAPABLE
- EN 161/EN ISO 23553-1
- DIN-DVGW

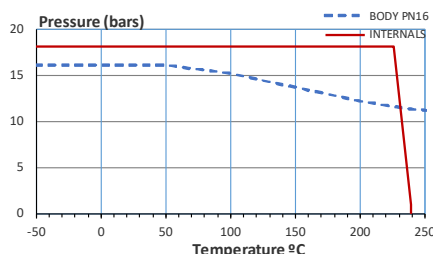

PEKOS GROUP CERTIFICATES:

ISO 9001: 2015 / 2014/68/EU / API-6D



DIMENSIONS & Technical information

DN	PN	D	L	E	A	B	C	F	H	G	V	X	Y	Z	n x d	ISO 5211	Torque	MAST	Weight
250	16	252	450	405	320	355	26	285	336	657	48	36	40	63	12 x 26	F14	950	2544	228
300	16	303	500	460	378	410	28	329	336	701	48	36	40	63	12 x 26	F14	1200	2544	321

** Depending on service conditions.

* Dimensions are in mm.

* Torque & MAST are in Nm.

* Weight is in Kilograms

* Torque values have been measured ΔP at maximum rating at room temperature