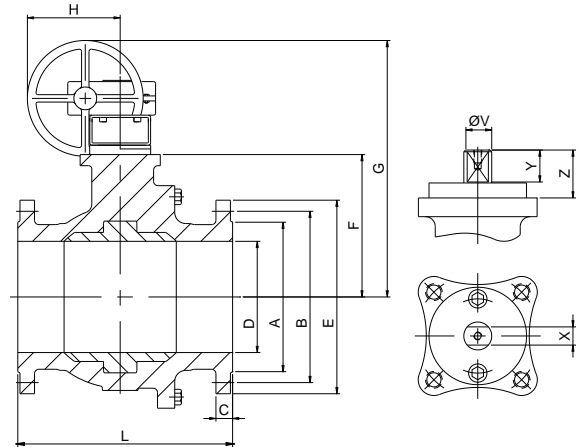
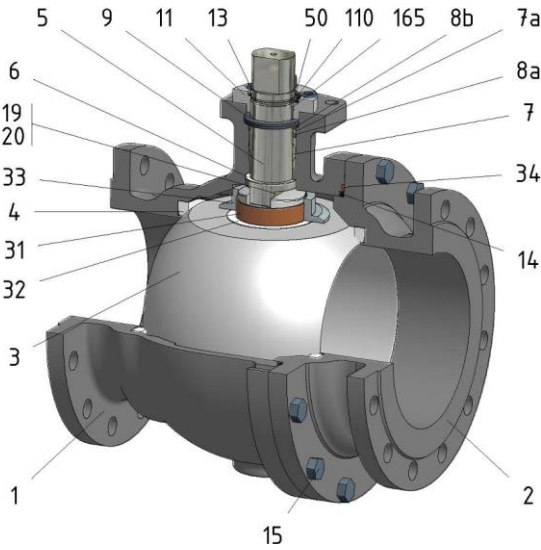

FIG.ZG 09 TTTG PN16 DN150/300 F5



Position	Description	Material
01	Body 1	C.S. 1.6220
02	Body 2	C.S. 1.6220
03	Ball	S.S. 1.4408
04	Seat	PTFE (modified)
05	Stem	S.S. 1.4401
06	Stem seal	PTFE (modified)+FG
07	Stem packing	PTFE (modified)
07a	Stem packing 2	Graphite
08a	Gland packing 1	S.S. 1.4401
08b	Gland packing 2	S.S. 1.4401
09	Spring washer	S.S. 1.4310
11	Cover	S.S. 1.4408
13	Cover bolt	A4-70
14	Body seal 1	PTFE (modified)
15	Body bolt	A2-70
16	Handle	WCB
17	Handle bolt	1.045(8.8)
19	Spring	S.S. 1.4401
20	Antistatic ball	S.S. 1.4401
23	Handle pin	S.S. 1.4021
24	Lengthening handle	S.S. 1.0254
31	Bearing	PTFE (modified)
32	Bearing disk	PTFE (modified)+FG
33	Support bearing	S.S. 1.4401
34	Body seal 2	Graphite
50	Subjection ring	S.S. 1.4301
110	Subjection ring seal	S.S. 1.4401 Nitrided
165	Stem bearing	PTFE (modified)+FG

**General features**

- Guided ball.
- Split body.
- Full bore.
- Soft seat.
- Bidirectional.
- Anti Blow out proof stem.
- Autoadjustable packing.
- Anti static device.
- Self-cavity pressure relief.

**Standards**

- Top flange ISO 5211
- Flanges EN 1092-01
- Face to face EN 558
- Testing EN-12266, ISO 5208
- Design EN-12516, ISO 17292

**Official approvals**

- CERTIFICATE FIRE SAFE
- TA-LUFT VDI 2440
- ISO 15848-1
- ATEX 2014/34/EU
- PED 2014/68/EU
- SIL 3 CAPABLE
- EN 161/EN ISO 23553-1

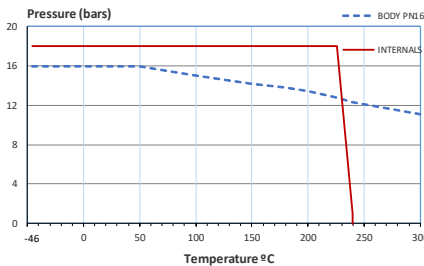

**PEKOS GROUP CERTIFICATES:**  
ISO 9001: 2015 / 2014/68/EU / API-6D



**DIMENSIONS & Technical information**

DN	PN	D	L	E	A	B	C	F	H	G	V	X	Y	Z	n x d	ISO 5211	Torque	MAST	Weight
150	16	150	350	285	212	250	22	175	271	497	36	27	35	50	8 x 22	F12	380	1074	83
200	16	201	400	340	268	320	24	245	336	617	48	36	40	63	12 x 22	F14	540	2544	147
250	16	252	450	405	320	355	26	285	336	657	48	36	40	63	12 x 26	F14	950	2544	228
300	16	303	500	460	378	410	28	329	355	707	48	36	40	63	12 x 26	F14	1200	2544	321

\*\* Depending on service conditions.

\* Dimensions are in mm.

\* Torque & MAST are in Nm.

\* Weight is in Kilograms

\* Torque values have been measured ΔP at maximum rating at room temperature