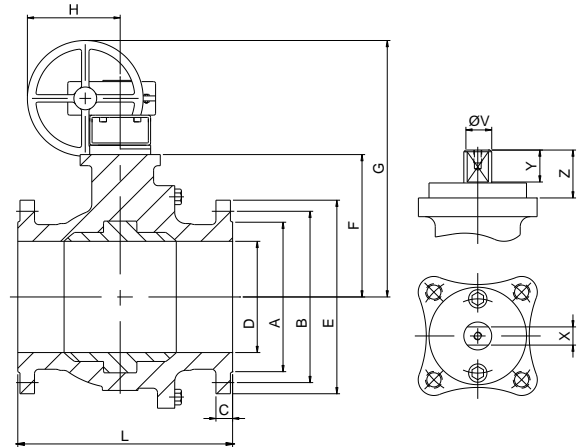
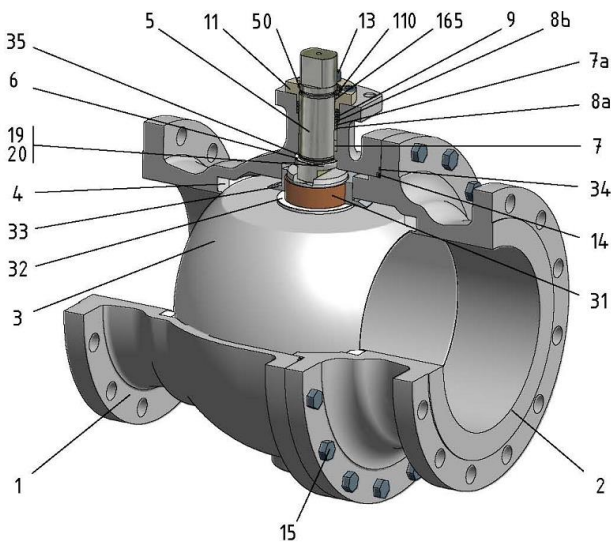

FIG.ZG 19 TTTGV CL150 6"-12"



Position	Description	Material
01	Body 1	C.S. A352 LCC
02	Body 2	C.S. A352 LCC
03	Ball	S.S. A351 CF8M
04	Seat	PTFE (modified)
05	Stem	S.S. AISI 316
06	Stem seal	PTFE (modified)+FG
07	Stem packing	PTFE (modified)
07a	Stem packing 2	Graphite
08a	Gland packing 1	S.S. AISI 316
08b	Gland packing 2	S.S. AISI 316
09	Spring washer	S.S. AISI 301
11	Cover	S.S. AISI 316
13	Cover bolt	S.S. (316)
14	Body seal 1	PTFE (modified)
15	Body bolt	A193 L7M
19	Spring	S.S. AISI 316
20	Antistatic ball	S.S. AISI 316
31	Bearing	PTFE (modified)
32	Bearing disk	PTFE (modified)+FG
33	Support bearing	S275JR+ENP
34	Body seal 2	Graphite
35	O ring stem	FKM
50	Subjection ring	S.S. AISI 304
110	Subjection ring seal	S.S. AISI 316 Nitrided
165	Stem bearing	PTFE (modified)+FG

General features

- Guided ball.
- Split body.
- Full bore.
- Soft seat.
- Bidirectional.
- Anti Blow out proof stem.
- Autoadjustable packing.
- Anti static device.
- Self-cavity pressure relief.

Standards

- Top flange ISO 5211
- Flanges ANSI B16.5
- Face to face ANSI B16.10
- Testing API 598, API 6D, BS 6755-1
- Design AP 6D, B16.34
- Materials according to NACE MR0175

Official approvals

- CERTIFICATE FIRE SAFE
- TA-LUFT VDI 2440
- ISO 15848-1
- API 6D.
- ATEX 2014/34/EU
- PED 2014/68/EU
- SIL 3 CAPABLE
- EN 161/EN ISO 23553-1

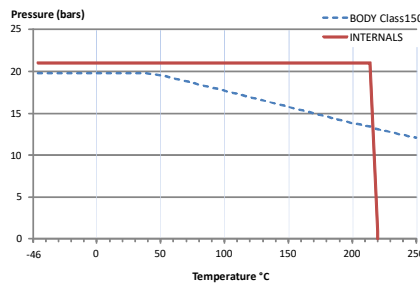

PEKOS GROUP CERTIFICATES:

ISO 9001: 2015 / 2014/68/EU /API-6D



DIMENSIONS & Technical information

DN	CL	D	L	E	A	B	C	F	H	G	V	X	Y	Z	n x d	ISO 5211	Torque	MAST	Weight
6"	150	150	394	280	216	241	27	176	268	499	36	27	35	50	8 x 22	F12	400	1047	81
8"	150	201	457	345	270	299	30	245	346	635	48	36	40	63	8 x 22	F14	720	2482	143
10"	150	252	533	405	324	362	32	285	346	675	48	36	40	63	12 x 25	F14	1160	2482	245
12"	150	303	610	485	381	432	33	329	396	769	48	36	40	63	12 x 25	F14	1322	2482	367

** Depending on service conditions.

* Dimensions are in mm.

* Torque & MAST are in Nm

* Weight is in Kilograms

* Torque values have been measured ΔP at maximum rating at room temperature