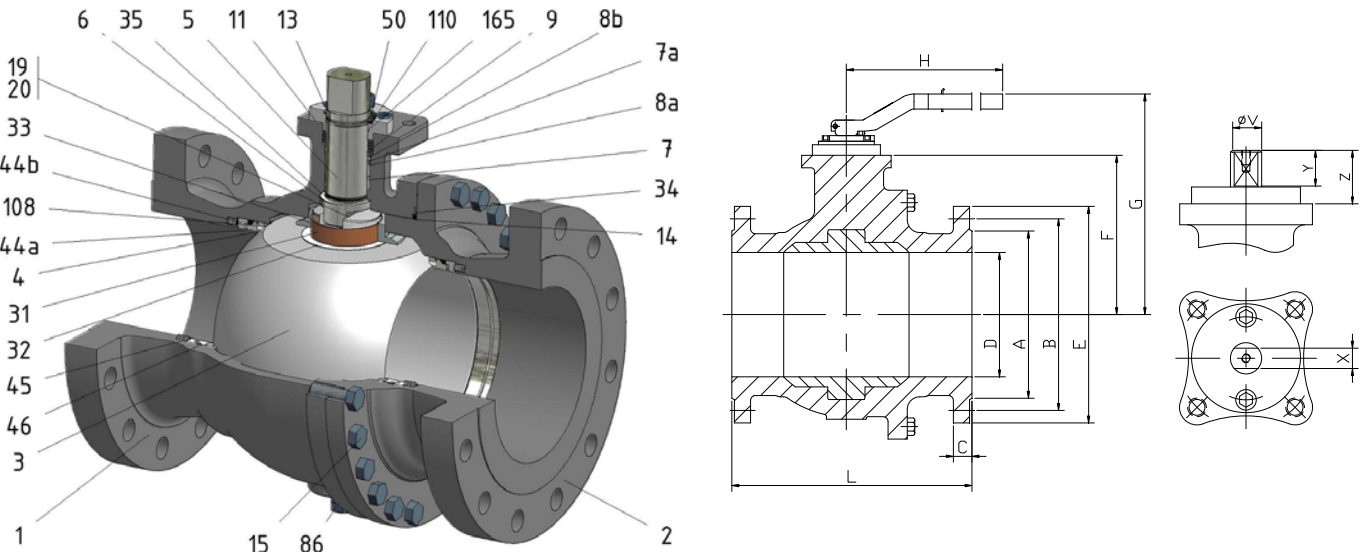

FIG.ZGS 14 SSSGV CL150 6"-12"



Position	Description	Material
01	Body 1	C.S. A216 WCC
02	Body 2	C.S. A216 WCC
03	Ball	S.S. A351 CF8M
04	Seat	PTFE (modified)+CG
05	Stem	A182 F51
06	Stem seal	PTFE (modified)+CG
07	Stem packing 1	PTFE (modified)+CG
07a	Stem packing 2	Graphite
08a	Gland packing 1	S.S. AISI 316
08b	Gland packing 2	S.S. AISI 316
09	Spring washer	S.S. AISI 301
11	Cover	S.S. A351 CF8M
13	Cover bolt	S.S. (316)
14	Body seal 1	PTFE (modified)+CG
15	Body bolt	A193 B7M
16	Handle	WCB
17	Handle bolt	1.045(8.8)
19	Spring	Inconel X750
20	Antistatic ball	Inconel 625
23	Handle pin	S.S. AISI 420
24	Lengthening handle	A570
31	Bearing	PTFE (modified)+CG
32	Bearing disk	PTFE (modified)+FG
33	Support bearing	S.S. AISI 316
34	Body seal 2	Graphite
35	O ring stem	FKM
44a	Ring seat 1	S.S. AISI 316
44b	Ring seat 2	S.S. AISI 316
45	Spring seat	Inconel X750
46	Seat seal	Graphite
50	Subjection ring	S.S. AISI 420
86	Drain plug	C.S. A350 LF2
86a	Vent plug	C.S. A350 LF2
108	O ring seat	FKM
110	Subjection ring seal	S.S. AISI 316 Nitrided
165	Stem bearing	PTFE (modified)+FG

General features

- Full trunnion.
- Split body.
- Full bore.
- Soft seat.
- Bidirectional.
- Spring loaded seat system.
- Anti Blow out proof stem.
- Autoadjustable packing.
- Anti static device.
- Self-cavity pressure relief.
- Double Block and Bleed.

Standards

- Top flange ISO 5211
- Flanges ANSI B16.5
- Face to face ANSI B16.10
- Testing API 598, API 6D, BS 6755-1
- Design API 6D, B16.34
- Materials according to NACE MR0175

Official approvals

- CERTIFICATE FIRE SAFE
- TA-LUFT VDI 2440
- ISO 15848-1
- ATEX 2014/34/EU
- API 6D.
- PED 2014/68/EU
- SIL 3 CAPABLE

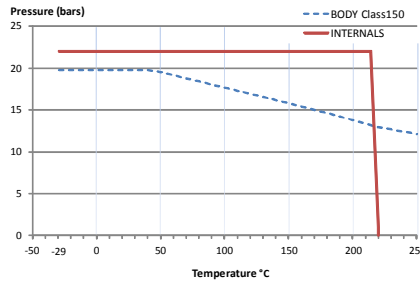

PEKOS GROUP CERTIFICATES:



DIMENSIONS & Technical information

DN	CL	D	L	E	A	B	C	F	H	G	V	X	Y	Z	n x d	ISO 5211	Torque	MAST	Weight
6"	150	150	394	280	216	241	27	176	740	285	36	27	35	44	8 x 22	F14-1	640	2356,2	100
8"	150	200	457	345	270	299	30	245	750	354	48	36	40	63	8 x 22	F16-1	990	5585,0	148
10"	150	250	533	405	324	362	32	285	-	-	48	36	40	63	12 x 25	F16-1	1340	5585,0	241
12"	150	300	610	485	381	432	33	329	-	-	48	36	40	63	12 x 25	F16-1	1660	5585,0	374

\*\* Depending on service conditions.

\* Dimensions are in mm.

\* Torque & MAST are in Nm

\* Weight is in Kilogram

\* Torque values have been measured ΔP at maximum rating at room temperature