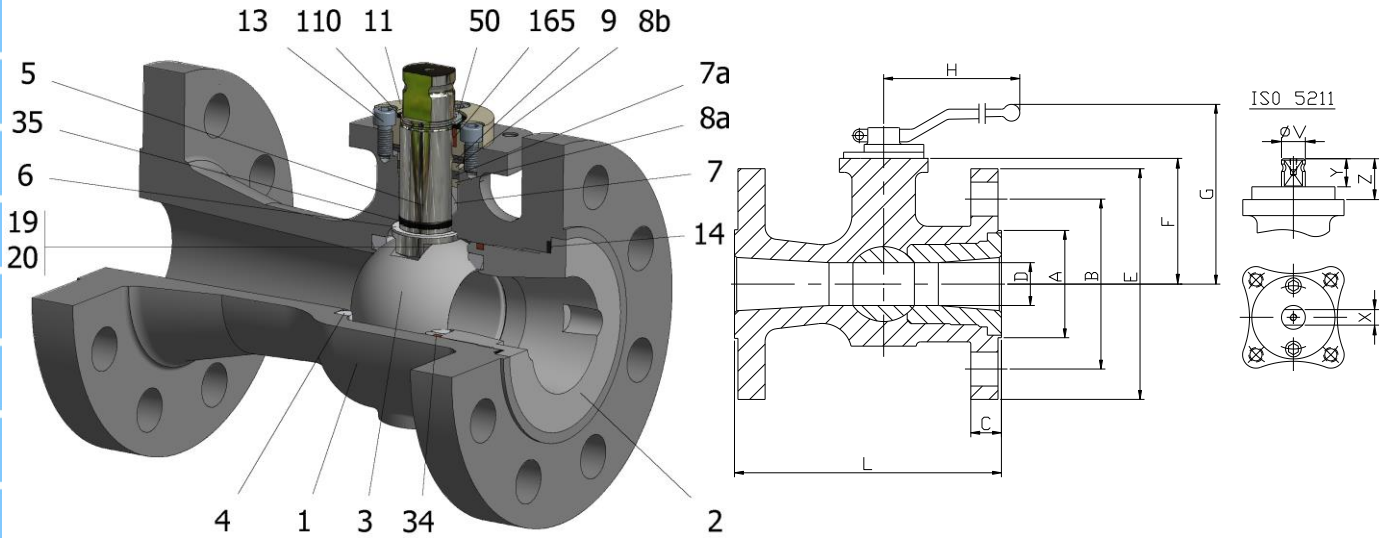

FIG.ZRB 39 SSGVV CL300 1"-6"



Position	Description	Material
01	Body 1	C.S. A352 LCC
02	Body 2	C.S. A350 LF2
03	Ball	S.S. A351 CF8M
04	Seat	PTFE (modified)+CG
05	Stem	S.S. AISI 316
06	Stem seal	PTFE (modified)+CG
07	Stem packing	PTFE (modified)+CG
07a	Stem packing 2	Graphite
08a	Gland packing 1	S.S. AISI 316
08b	Gland packing 2	S.S. AISI 316
09	Spring washer	S.S. AISI 301
11	Cover	S.S. A351 CF8M
13	Cover bolt	S.S. (316)
14	Body seal 1	Graphite
16	Handle	WCB
17	Handle bolt	1.045(8.8)
19	Spring	S.S. AISI 316
20	Antistatic ball	S.S. AISI 316
34	Body seal 2	FKM
35	O ring stem	FKM
50	Subjection ring	S.S. AISI 420
110	Subjection ring seal	S.S. AISI 316 Nitrided
165	Stem bearing	PTFE (modified)+FG

**General features**

- Floating ball.
- End entry.
- Reduced bore.
- Soft seat.
- Bidirectional.
- Anti Blow out proof stem.
- Autoadjustable packing.
- Anti static device.
- Self-cavity pressure relief.

**Standards**

- Top flange ISO 5211
- Flanges ANSI B16.5
- Face to face ANSI B16.10
- Testing API 598, API 6D, BS 6755-1
- Design API 6D, B16.34
- Materials according to NACE MR0175

**Official approvals**

- CERTIFICATE FIRE SAFE
- TA-LUFT VDI 2440
- ISO 15848-1
- API 6D.
- ATEX 2014/34/EU
- PED 2014/68/EU
- SIL 3 CAPABLE
- EN 161/EN ISO 23553-1

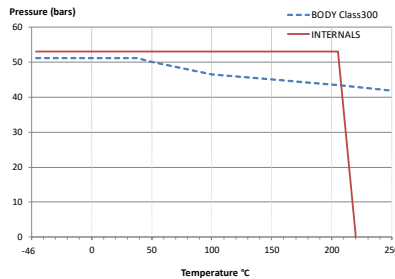

**PEKOS GROUP CERTIFICATES:**

ISO 9001: 2015 / 2014/68/EU / API-6D



**DIMENSIONS & Technical information**

DN	CL	D	L	E	A	B	C	F	H	G	V	X	Y	Z	n x d	ISO 5211	Torque	MAST	Weight
1"	300	20	165	125	51	89	18	47	185	110	14	11	11	13,5	4 x 19	F05	16	42	5
1 1/2"	300	32	190	155	73	114	22	57	185	120	18	14	17	19,5	4 x 22	F05	32	92	8
2"	300	40	216	165	92	127	23	75	293	147	22	17	20	30	8 x 19	F07	42	244	12
3"	300	65	282	210	127	168	29	96	293	168	22	17	20	30	8 x 22	F07	90	244	22
4"	300	80	305	255	157	200	32	114	450	204	28	22	22	40	8 x 22	F10	150	510	38
6"	300	111	403	320	216	270	37	149	740	261	36	27	35	50	12 x 22	F12	420	1047	72

\*\* Depending on service conditions.

\* Dimensions are in mm. \* Torque & MAST are in Nm \* Weight is in Kilograms

\* Torque values have been measured ΔP at maximum rating at room temperature