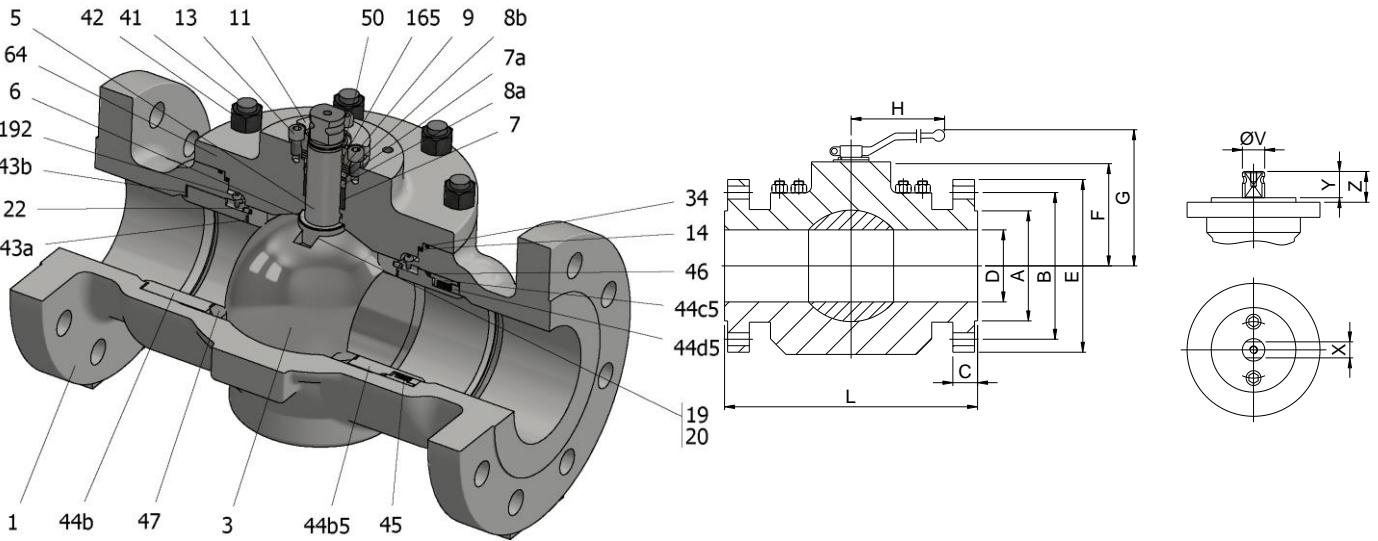

FIG.ZTEMS 14 CGGG CL150 1"-4"



Position	Description	Material
01	Body 1	C.S. A216 WCC
03	Ball	AISI 316+Cr-Carbide
05	Stem	XM-19
06	Stem seal	S.S. AISI 316 Nitrided
07	Stem packing	Graphite
07a	Stem packing 2	Graphite
08a	Gland packing 1	S.S. AISI 316
08b	Gland packing 2	S.S. AISI 316
09	Spring washer	Inconel X718
11	Cover	S.S. A351 CF8M
13	Cover bolt	S.S. (316)
14	Body seal 1	Graphite
16	Handle	A351 CF8M/WCB
17	Handle bolt	S.S. (304)/1.045(8.8)
19	Spring	S.S. AISI 316
20	Antistatic ball	S.S. AISI 316
22	Stop pin	S.S. AISI 316
34	Body seal 2	Graphite
41	Stud	A320 L7M
42	Nut	A194 7M
43a	Seat seal 1	Graphite+AISI 316
43b	Seat seal 2	Graphite+AISI 316
44b	Ring seat 2	S.S. AISI 316
44b5	Ring seat 2 (spring)	S.S. AISI 316
44c5	Ring seat 4 (spring)	S.S. AISI 316
44d5	Ring seat 3 (spring)	S.S. AISI 316
45	Spring	Inconel X750
47	Metal seat	S.S. AISI 316
50	Subjection ring	S.S. AISI 316
64	Body cover	C.S. A216 WCC
165	Stem bearing	Carbongraphite
192	Positioner bolt	S.S. (316)

General features

- Floating ball.
- Top entry
- Full bore.
- Metal to Metal.
- Bidirectional.
- Anti Blow out proof stem.
- Anti static device.
- Self-cavity pressure relief.
- Allows in-line maintenance

Standards

- Top flange ISO 5211
- Flanges ANSI B16.5
- Face to face ANSI B16.10
- Testing API 598, API 6D, BS 6755-1
- Design API 6D, B16.34
- Materials according to NACE MR0175

Official approvals

- CERTIFICATE FIRE SAFE
- TA-LUFT VDI 2440
- ATEX 2014/34/EU
- API 6D.
- ISO 15848-1
- PED 2014/68/EU
- SIL 3 CAPABLE

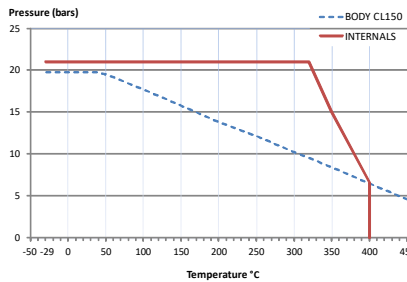

PEKOS GROUP CERTIFICATES:



DIMENSIONS & Technical information

DN	CL	D	L	E	A	B	C	F	H	G	V	X	Y	Z	n x d	ISO 5211	Torque	MAST	Weight
1"	150	25	216	110	51	80	12	67	185	124	18	14	17	19,5	4 x 16	F05	40	175	8
1 1/4"	150	32	229	115	64	89	14	14	185	128	18	14	17	19,5	4 x 16	F05	60	175	10
1 1/2"	150	40	241	125	73	98	15	87	293	157	22	17	20	30	4 x 16	F07	80	464	14
2"	150	50	292	150	92	121	17	95	293	165	22	17	20	30	4 x 19	F07	106	464	22
2 1/2"	150	65	330	180	105	140	18	105	293	175	22	17	20	30	4 x 19	F07	180	464	32
3"	150	80	356	190	127	152	20	126	450	230	28	22	22	40	4 x 19	F10	300	969	48
4"	150	100	432	230	157	191	25	139	450	243	28	22	22	40	8 x 19	F10	360	969	69

** Depending on service conditions.

* Dimensions are in mm.

* Torque & MAST are in Nm

* Weight is in Kilograms

* Torque values have been measured ΔP at maximum rating at room temperature