

 **Pekos**
Ball Valves

www.pekosvalves.com

Valve Automation



Making excellence
something personal



Pekos Automation division provides complete valve sizing and automation for industrial processes.

Valve sizing and automation based on customer's requirements according to:

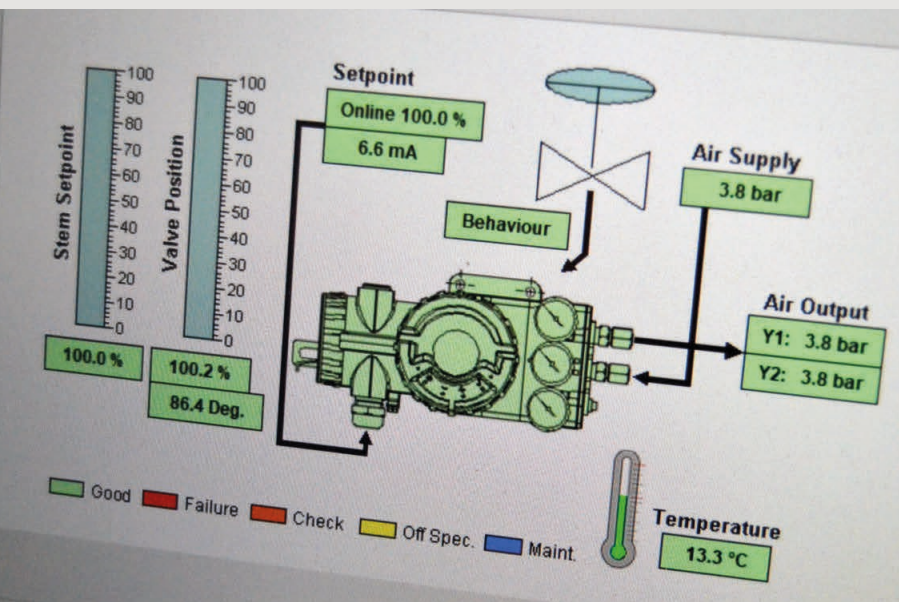

- Redundant configuration control.
- ATEX/SIL Classification.
- International standards for specific applications.
- Passive Fire Protection.
- Partial Stroke Test devices.
- Air tank sizing for emergency operating.
- Fast Stroke Sizing

Valve Automation

Pekos Automation Center

The Pekos Automation Center is fully dedicated to valve automation. The building adds 1700 sq/mt to our assets and is equipped with assembling area, 25 TN crane, test bench, warehouse and offices.

Our extensive capabilities and high stock levels ensure fast product availability, allowing us to deliver automated packages within few days. Our goal is offering the expertise and service to our partners worldwide.



STOCK Available

30M € stock in valves, actuators & automation complements.

Fast track service.

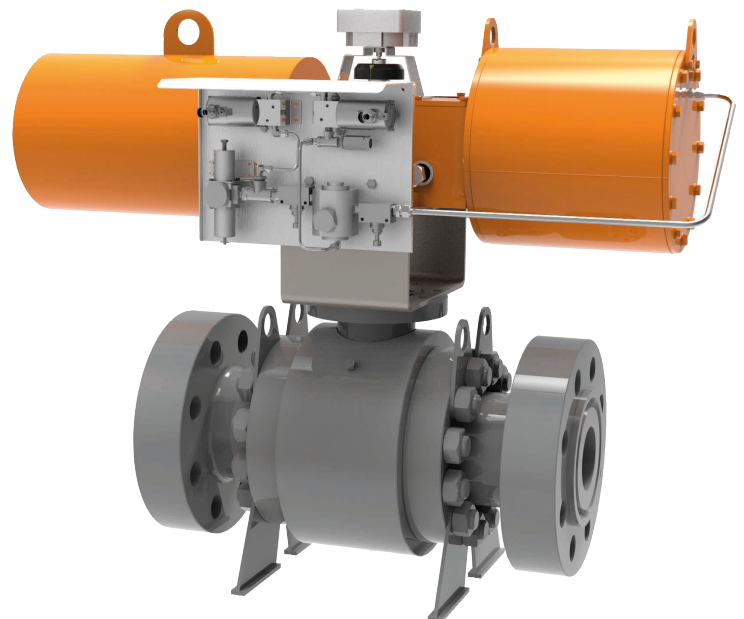

Actuators

Pekos Valves automation division offers all types of actuator assembly; 0-90° up to 180° rotative actuators (pneumatic, hydraulic, electric, Gas over oil, Direct Gas, etc.).



RACK & PINION

- Pneumatic
- Single/Double Acting
- 0-90° up to 180°
- Low/Medium Torque

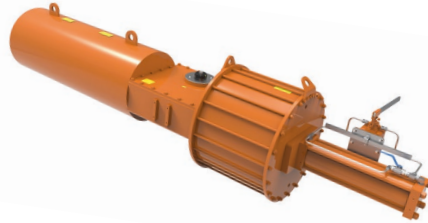

SCOTCH YOKE

- Pneumatic / hydraulic
- Single/Double Acting
- 0-90°
- Low High Torque

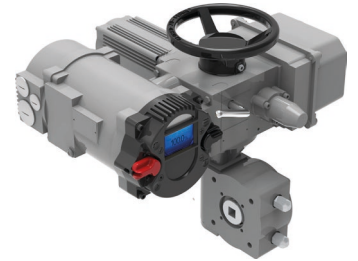

ELECTRIC

- 0-90° up to 180° (or multiturn)
- Power unit: 24 Vdc, 230 Vac, 400 Vac, others
- Control unit: 24 Vdc, 230 Vac, others
- Low / High torque



GAS OVER OIL

- Hydraulic
- Double Acting
- 0-90° (up to 180° optional)
- High Torque

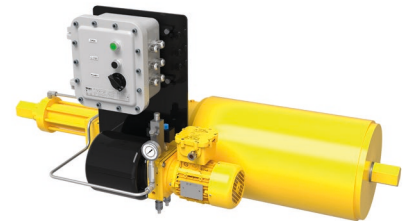

HYDRAULIC ELECTRO-HYDRAULIC

- Rack & Pinion
- Scotch Yoke
- Single/ Double Acting 0-90°
- Low / High Torque

Automation Accessories

On board or remote control panels available

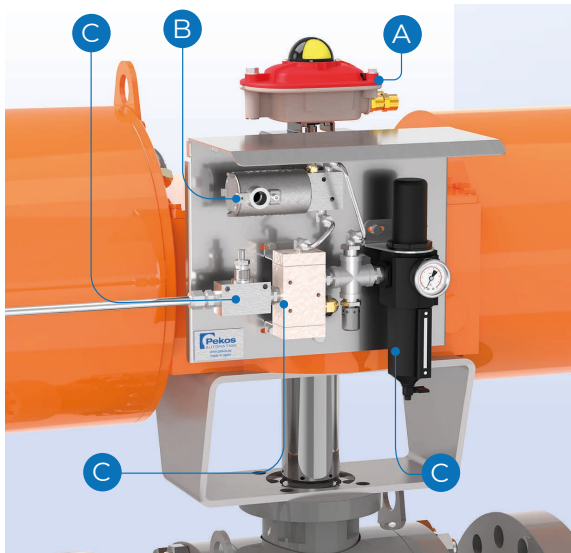

A - LIMIT SWITCH

- Limit switch boxes with visual position indicators
- Sensor Types: Mechanical / Magnetic / Inductive / Pneumatic
- Available with ATEX (Exia, Exd, Exed) SIL certificates
- Aluminium, stainless steel and vestamid housing covers

B - SOLENOIDS

- In-line / NAMUR assembly according to VDI/VDE 3845 available
- For single / double acting
- Working temperature range: -60°C up to +90°C
- DC / AC available
- Brass, Aluminium or Stainless steel body
- IP65-IP68 Protection
- ATEX / IECEx/FM
- SIL

C - PNEUMATIC ELEMENTS

- Pneumatic Valves 2/2, 3/2, 5/2, 5/3.
- Filter Regulator
- Booster
- Quick Exhaust
- Thermal Fuse (Fire protection)
- Pressure Switches
- Relief valves
- Check valves
- Lock up valves

D - POSITIONER

- Pekos Ball Valves supplies universal positioners that provide versatility, dynamic performance, and high positioning accuracy
- Assembled on top, in contact with the actuator, with the same rotary movement
- Available for hazardous zones, SIL and other certificates

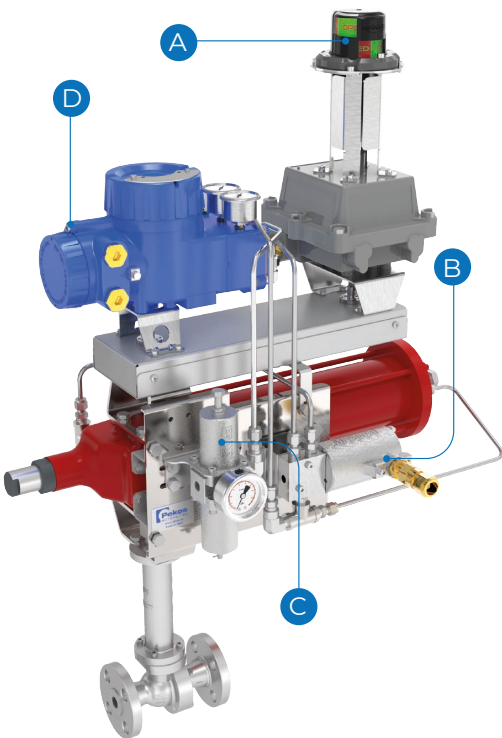

Pneumatic Positiones

- 3 to 15 psi signal

Electro-pneumatic Positione

- 4-20 mA signal
- Optional, 4-20 mA feedback signal

Smart Positioneer

- Self-Calibration.
- Communication protocol: Hard, Profi bus, and others.
- Optional, 4-20 mA feedback signal PST Function.

E - EMERGENCY MANUAL OVERRIDE

- For single and double acting actuators. Manual Override system available.



Valve Automation

SETTING PARAMETERS

DETECTION / TEST DEVICES

- Limit Switch - Sensor Types SIL
- ATEX
- Partial Stroke Test
- Positioners

ACTUATORS

- Pneumatic / Hydraulic / Electric
- Electro-hydraulic / Gas over Oil
- SIL
- ATEX

CONTROL PANEL TYPES REQUERIMENTS

- SIL
- ATEX
- Stroking Times
- Different Control Configuration Available

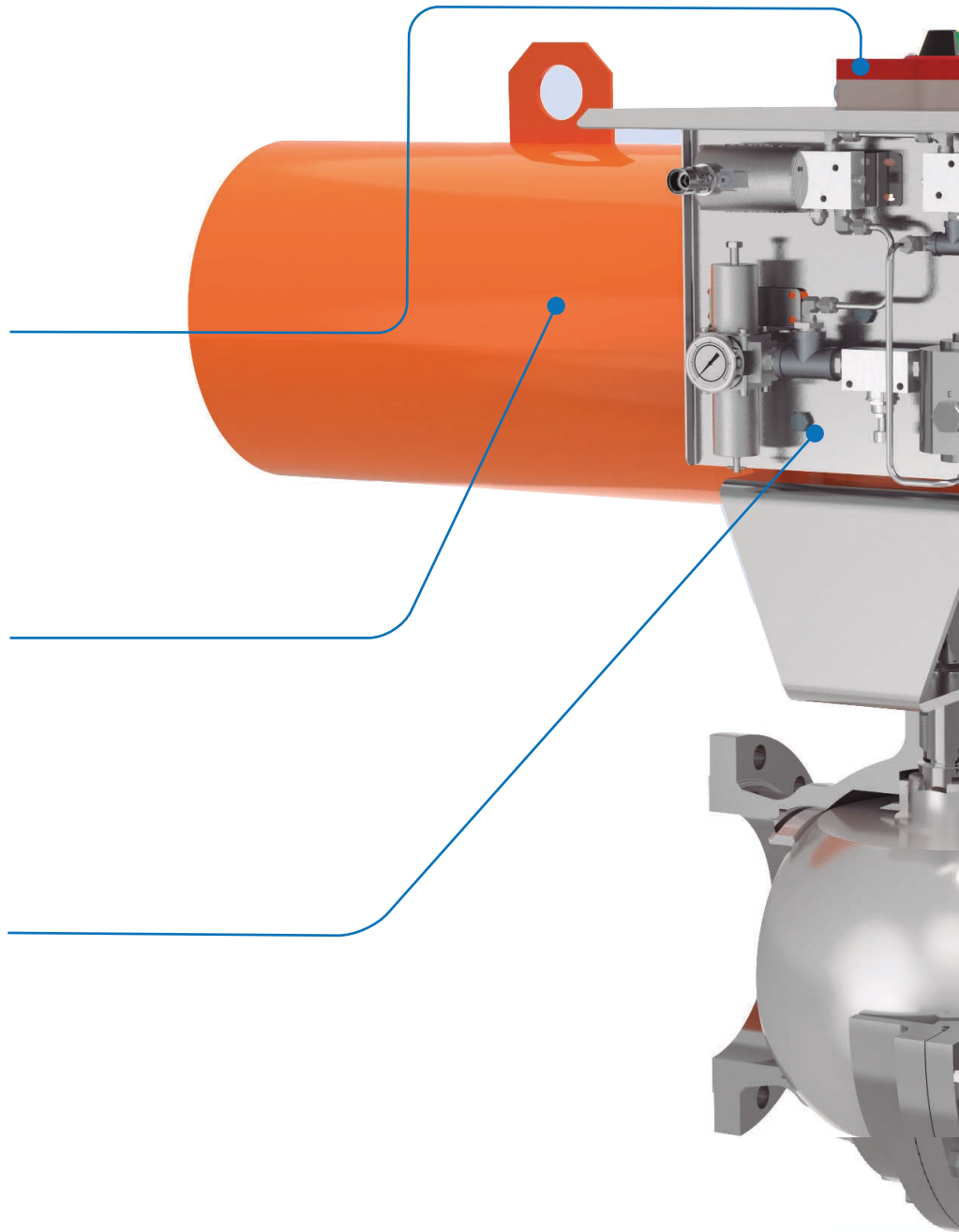

Solenoid Configuration

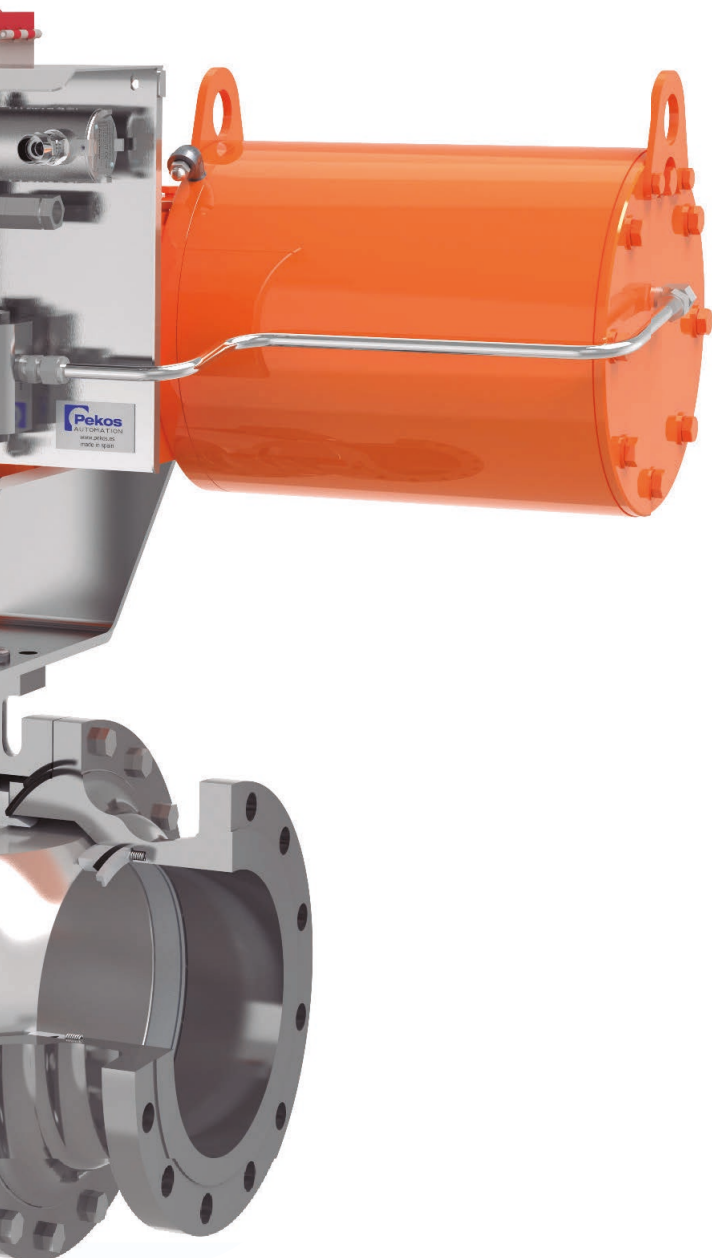

1001 Configuration

Only 1 solenoid
3/2 Solenoid - Single Acting
5/2 Solenoid, Monostable — Double Acting

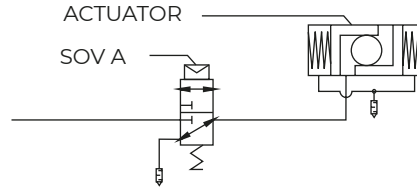

SOV A	ACTUATOR
Single Acting	
On	Open
Off	Close
Double Acting	
On	Open
Off	Close

1002 Redundant Configuration

2 solenoid connected in series - Single Acting
SAFETY
The air has one way to reach the actuator

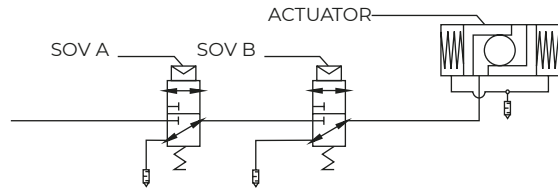

SOV A	SOV B	ACTUATOR
On	On	Open
On	Off	Close
Off	On	Close
Off	Off	Close

2002 Redundant Configuration

2 solenoid connected in parallel - Single Acting
AVAILABILITY
The air has one way to reach the actuator

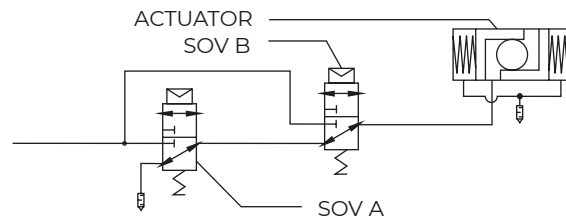

SOV A	SOV B	ACTUATOR
On	On	Open
On	Off	Open
Off	On	Open
Off	Off	Close

Process Function

ESDV Emergency Shut-Down Valve / SDV Shut-Down Valve

- ON-OFF valve intended for emergency situations.
- Long periods of time at the same position (opened) until an emergency occurs.
- Required stroking times, especially for safety position.
- Single acting actuators. FAIL CLOSE.
- Manual reset solenoids.
- Pneumatic control configuration: 1oo1, 1oo2.
- PST / SIL / Hazardous locations.
- An ESDV valve is controlled by the Emergency Shut-Down system (ESD/SIS)

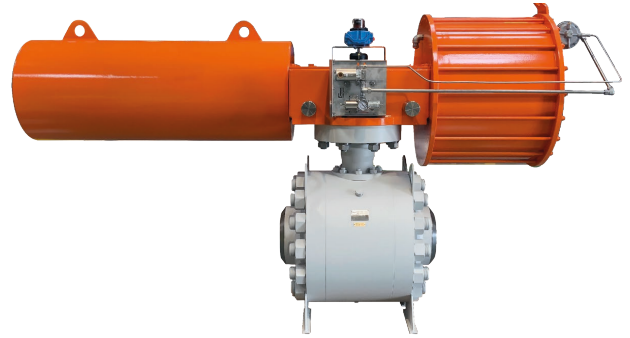

BDV Blow Down Valves

- Valve intended for venting the pipeline.
- Assembled with an air tank to ensure valve operability during emergency situations.
- Required stroking times.
- Single acting actuators. FAIL OPEN.
- Pneumatic control configuration: 1oo1, 2oo2.
- Hazardous locations.
- A BDV valve is controlled by the Emergency Shut-Down system (ESD/SIS).
- PST / SIL / Hazardous locations

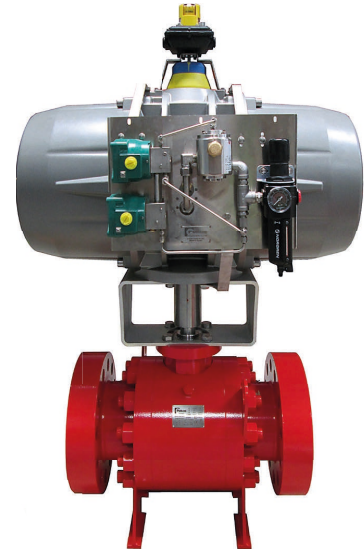

BDV Standard Air Tank Parts

- Pressure Switch
- Gauge
- Lock-Up Valve
- Check Valve
- Drain Valve
- Safety Valve



XV Process Valve

- 2, 3 or 4 way valve / V-Port
- Process ON-OFF valve controlled by the Process Control System (PCS).
- Required stroking times.
- Single acting / double acting actuators.
- Pneumatic control configuration:
 - 1oo1, 1oo2, 2oo2, etc.
 - PST
 - SIL.
- Hazardous locations.



MOV Motor Operated Valves

- Process ON-OFF valve controlled by Process Control System (PCS).
- Hazardous Locations.
- SIL for ESDV applications with fail safe actuators.
- HART, Profibus and others.
- Stroking Times.
- Manual Override.





Lloyd's Type Approval Certificate EN 161, class A, & EN 23553 (former EN 264), for Pekos Ball valves, with Air Toque actuators, assembled at Pekos facilities.



EU type examination type certificate for regulation (EU) 2016/426 to appliances burning gaseous fuels.

Equipment description:

- Actuator: Torque Value.
- Solenoid Cv: 0,3; II 2G Ex e mb II C T6
- Quick Exhaust Cv: 1.6
- Air supply pressure: 5 bar
- PEKOS ball valve: Z06 TTTG- PN40 DN50
- Ambient temp. limitation: -25°C up to +80°C

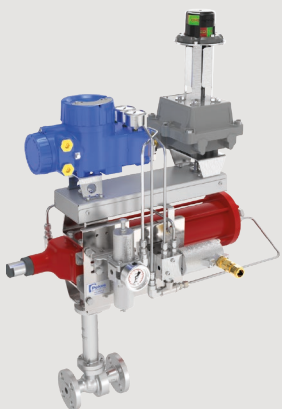
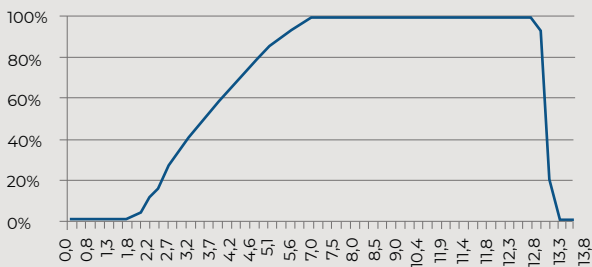

Remote Control Mode
Smart Positioner/
Transmitter
Communication
Protocol
(HART, PROFIBUS, etc.).

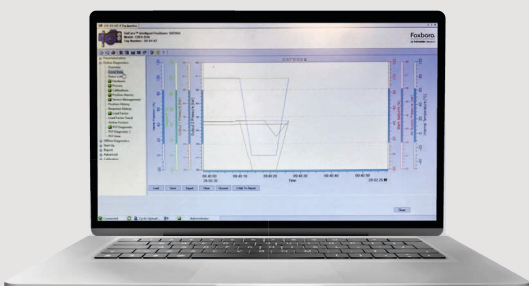

PST Signature and Full Stroke Signature

Certified assembly for automatic valve according to EN161, EN16678 & EN23553

EN161, EN16678 & EN23553

EN 161, EN 16678

Automatic shut-off valves for gas burners and gas appliances.

EN 23553

Safety and control devices for oil burners and oil-burning appliances.

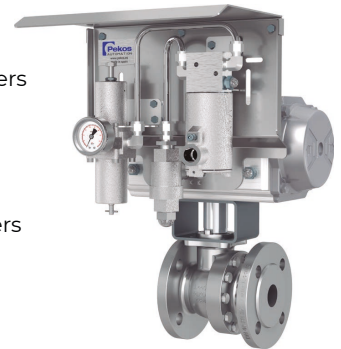

Automation main requirements:

- Safety factor: 250% (EN 161)
- Closing <1 second (EN 161)
- Valve max. shut-off pressure: 5 bar for EN 161; 63 bar for EN 16678; 50 bar for EN 23553
- The actuator must close considering the maximum valve shut-off pressure with the minimum air supply available
- The solenoid valves must be operative considering +/- 15% of the nominal voltage

PST Partial Stroke Test

Non-intrusive test for safety prevention

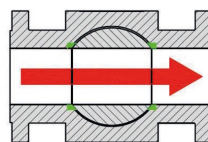

1° stage
Valve in working position.

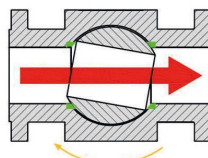

2° stage
PST operation
(PST set point achieved)
10% rotation

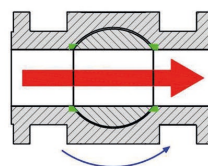

3° stage
valve back to working
position (non-emergency
situation).

The PST does not affect the fluid flow (red arrow). The PST allow us to reach and maintain the required system's SIL level.



Passive fire protection

General Standard Equipment

Protect parts 1093°C/2000°F during 30 minutes. Result: After the test, the protected parts must to be operative and will keep its operational features.

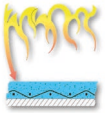

As the fire starts:
Starts to react at 85.6°C. A chemical process causes the coating to expand (intumesce). Evaporation on the surface then takes place which also has a cooling effect. The outside surface then starts to char.

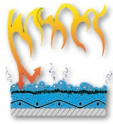

During the fire:
The surface char deepens reflecting 80-90% of the heat back into the fire. More intumescence takes place which forms a barrier which both insulates and has a cooling effect.

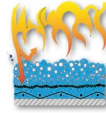

Long term exposure:
The 1093°C heat will penetrate the first layer so that the protection below will start to react. The next layer reacts as before. The layers react until the fire is extinguished or the material is consumed.



Coating assembled on the valve/actuator/devices at delivery. Easy maintenance without disassemble protection.

Application Types

SURFACE COATING
Applied directly over all external surfaces of the parts which are going to be protected against the fire. The coating is fixed to the surfaces permanently. This protection systems allows to perform any kind of maintenance operations.



MODULAR SYSTEM
The modular system consists of two parts which covers and protects the equipment. Both parts are adapted to the external shape of the equipment, reducing all the possible gaps between protected parts, allowing to perform any kind of maintenance.



Blankets

UL-1709, certified fire protection against fire during 30 minutes up to 1093°C.

Blankets must be assembled once the valve is set up at the pipeline





Valve Automation



ISO 9001
ISO 14001
ISO 45001



BS6364
CRYOGENIC SERVICE



IEC 61508



ANSI 372



EN 161
EN ISO 23553-1



FIRE SAFE



API 6D - 0363



VALVES . PIPING SYSTEMS
LIQUEFIED GAS TANKERS



LOW FUGITIVE EMISSION
TA Luft
VDI 2440
ISO 15848-1



TÜV. AR . 352
TANK OF DANGEROUS
PRODUCTS



EN 13774



AD-MERKBLATT WO/TRD



REGISTER 204863



PED 2014/68/EU
CATEGORY III, MODULE H



AUSTRALIAN GAS
ASSOCIATION
CERTIFIED PRODUCT

CRNCanada

Certificate of Authorization issued by ABSA



ATEX DIRECTIVE
014/34/EU



EN 16678
EN 161