

Ball Valves **METAL SEATED**

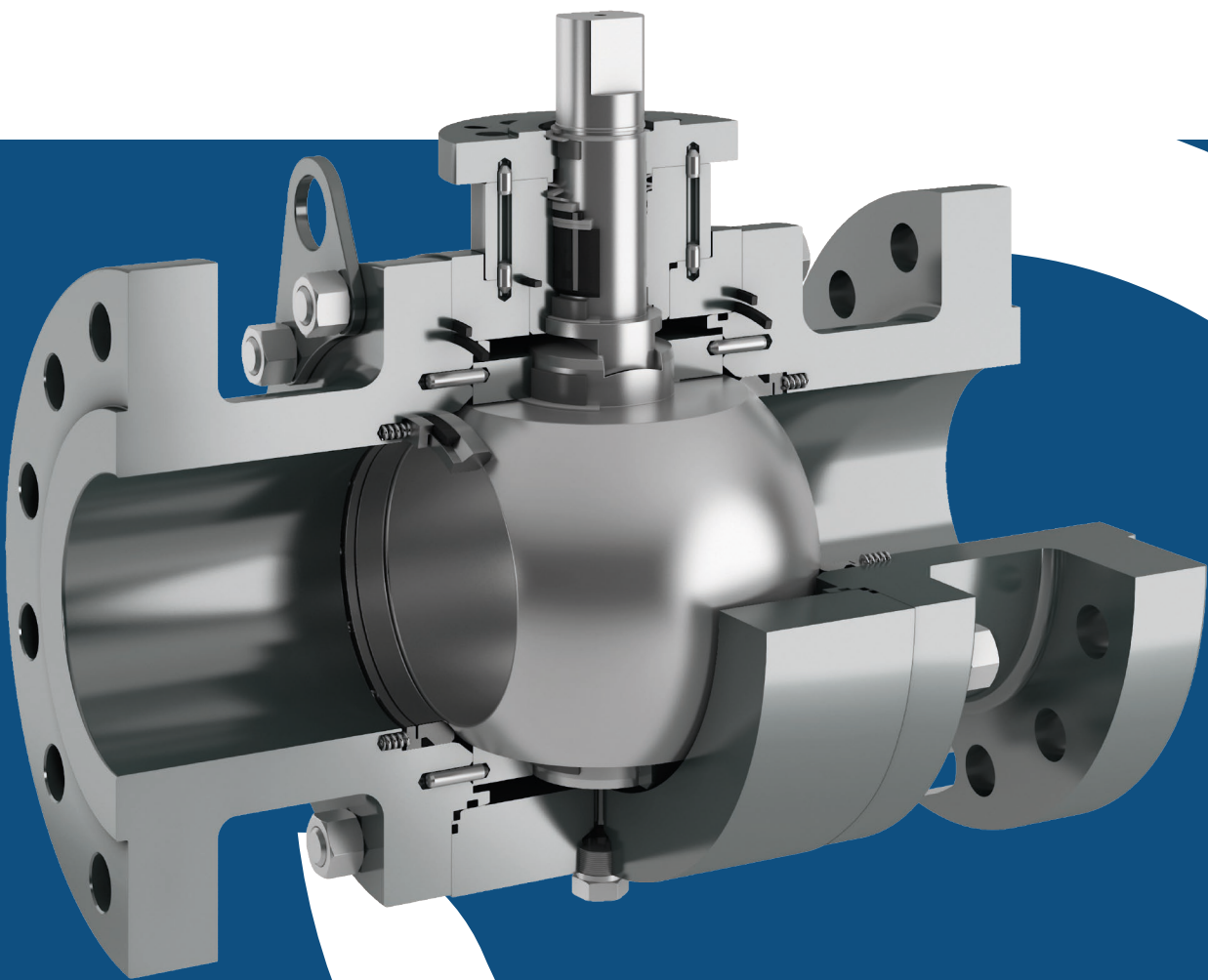

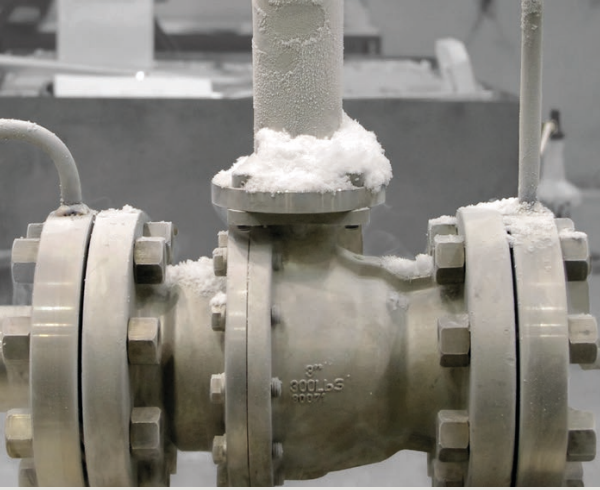

Certificates of the company

ISO 14001	Environmental Management System
ISO 9001	Quality Management system
API Monogram	API Q1 & API-6D
ISO 45001:2018	Health & Safety

Certificates of the product

DNV	Type approval
Lloyd's Register	Fire Safe & Type Approval
TÜV A352.09 AD Merkblatt A4	Design of the valves
TA - Luft ISO15848-1 + VDI2440	Stem Tightness for gas emissions
Helium -40 °C	Leeds University test
Directive 2014/68/EU	Pressure equipment directive (CE marking)
Directive 2014/34/EU	ATEX - directive (II2GD c T-)
BS 6364	Valves for Cryogenic Service -196°C
EN 161 / EN 23553 / EN 16678	Automatic quick shut-off valves for Gas/Oil burners and equipment
EAC	TR CU 010 - TR CU 012 - TR CU 032
Sanitary approval (Russian)	Food processing and Pharmaceutical industry
IEC 61508	SIL3 CAPABLE
UKR SEPRO	Ukraine Certificate
DVGW-EN 13774	Valves for gas distribution with MOP 16 bar
API 6D Monogram	Certificate N° 6D-0363
NSF International	ANSI 372
CRN Canada	Registration certificate for Canada

Certifications and tests

- Fire Safe
- Cryogenic Test

Some Company Approvals

- Repsol-YPF (Spain)
- Al Furat Petroleum (Syria)
- Sasol Technology (South Africa)
- EGPC (Egypt)
- China Petroleum (China)
- OMV / Petrom
- Borealis
- Solvay
- Qatar Petroleum (Qatar)
- Petroleum Development Oman (PDO)
- KUWAIT Oil Co. (KOC)
- Zadco (UAE)
- ADNOC
- INOVYN / INEOS
- Neste



General Features

- Floating Ball / Trunnion
- Split body / End Entry / Top Entry
- Full / Reduced bore
- Bidirectional
- Self-cavity pressure relief
- Zero Leakage Class VI according to ANSI FCI 70-02 upon request.
- Spring loaded seat
- Anti Blow out stem
- Antistatic device
- DBB / DIB
- Auto adjustable packing

Coating Materials

Chrome Carbide (CrC)

Chrome Carbide is the standard coating for Pekos ball valves, it is well suited to very high temperature gas or liquid applications and has excellent resistance to wear, erosion and corrosive media. It has certain limitations in chlorine services and wet sulfur.

Hard Chromium (HCr)

Hard Chromium is suited to a wide range of applications in liquids and gases. It is limited to moderate pressures and temperatures. HCr is not suitable for strong acids and, fluids with high chloride content.

Tungsten Carbide (WC-Co)

Tungsten Carbide is very resistant to wear and erosion from slurries, powders, and muds. It works well in cryogenic applications, hydrocarbon gases and liquids, oxygen and dry gas services. It has limitations in corrosive services and condensates.

Cobalt Based Alloy

Cobalt based coating (Stellite) provides an excellent mechanical wear resistance, superior corrosion resistance and a good performance in high temperature (up to 535°C). Stellite is used in a lot of applications in pulp and paper industries and refining applications.

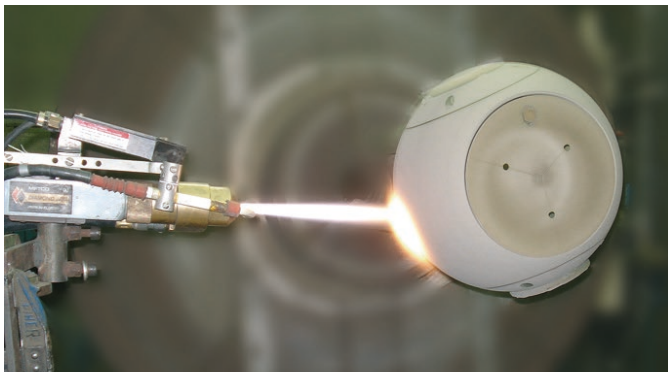

Coating

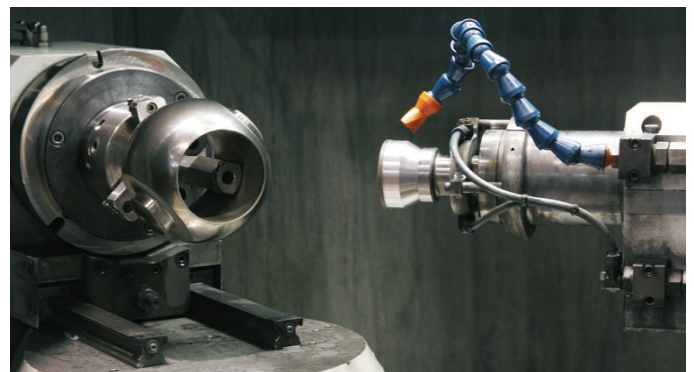

Grinding

Standards

- Top flange ISO 5211
- Flanges ASME B16.5, EN 1092-1
- Face to face ANSI B16.10, EN 558
- Testing API 598, API 6D, BS6755-1, EN-12266, ISO 5208, ANSI FCI 70-02
- Design API 6D, B16.34, EN-12516, ISO 17292
- Materials according to NACE MR0175
- Leakage Class V Standard according to ANSI FCI 70-02



FLOATING

ZMV

 220°C

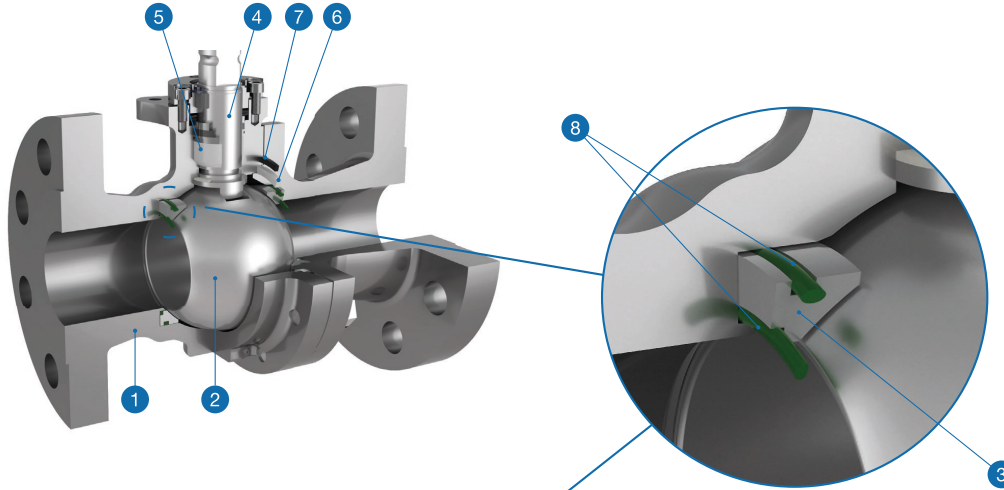

ZMVRB

 220°C

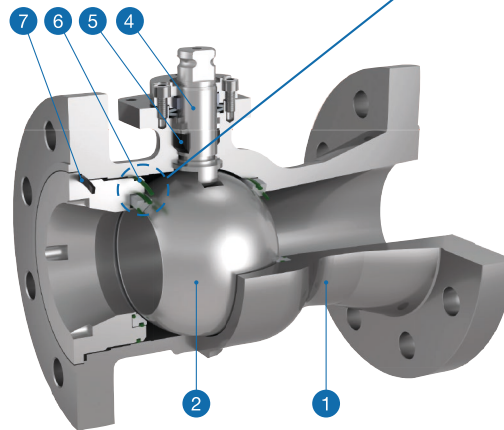

Standard Materials

Item	Description	ZMV & ZMVRB (ANSI)*		ZMV (DIN)*	
		Carbon steel	Stainless steel	Carbon steel	Stainless steel
1	Body	A216 WCC / A352 LCC	A351 CF8M	1.0619 / 1.6220	1.4408
2	Ball	CF8M + Cr-Carbide		1.4408 + Cr-Carbide	
3	Seat	AISI 316 + Cr-Carbide		1.4401 + Cr-Carbide	
4	Stem	XM-19		XM-19	
5	Stem packing 2	RPTFE		RPTFE	
6	Body Seal 1	RPTFE / FKM		RPTFE	
7	Body Seal 2	Graphite		Graphite	
8	O-ring	FKM		FKM	

Range

ZMV	
SIZE	RATING
DN 15 - 200	PN 10 - 16
DN 15 - 125	PN 25 - 40
DN 15 - 50	PN 63 - 100
1/2" - 8"	Class 150
1/2" - 4"	Class 300
1/2" - 2"	Class 600
ZMVRB	
SIZE	RATING
1/2" - 10"	Class 150
1/2" - 6"	Class 300

General Features

- Floating
- Split Body
- Full bore
- Soft seat / Metal seat
- Unidirectional / Bidirectional
- Anti blow out proof stem
- Anti static device
- Self-cavity pressure relief
- Degreased
- Cryogenic stem extension
- Allows in-line maintenance
- Auto adjustable packing



**FLOATING
ZMS**

 **400°C**
↑ Up to 640°C with F stem Extension

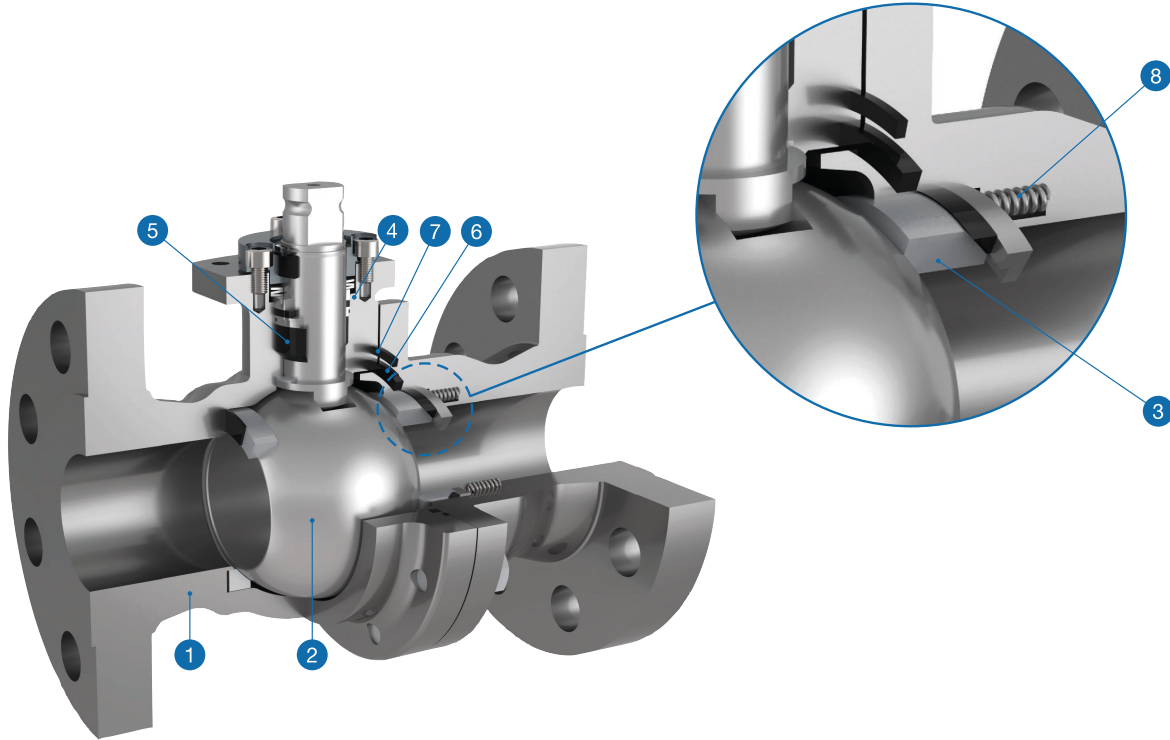

Standard Materials

Item	Description	ANSI*		DIN*	
		Carbon steel	Stainless steel	Carbon steel	Stainless steel
1	Body	A216 WCC / A352LCC	A351 CF8M	1.0619 / 1.6220	1.4408
2	Ball	CF8M + Cr-Carbide		1.4408 + Cr-Carbide	
3	Seat	AISI 316 + Cr-Carbide		1.4401 + Cr-Carbide	
4	Stem	XM-19		XM-19	
5	Stem packaging 2	Graphite		Graphite	
6	Body Seal 1	Graphite		Graphite	
7	Body Seal 2	Graphite		Graphite	
8	Spring Seat	Inconel X750		Inconel X750	

* Other material construction for different service upon request

Range

ZMS	
SIZE	RATING
DN 15 - 200	PN 10 - 16
DN 15 - 125	PN 25 - 40
DN 15 - 50	PN 63 - 100
1/2" - 8"	Class 150
1/2" - 4"	Class 300
1/2" - 2"	Class 600

General Features

- Floating ball
- Full bore
- Split body
- Bidirectional
- Anti blow out stem
- Auto-adjustable packing
- Anti static device
- Self-cavity pressure relief
- Spring loaded seat / Floating
- Leakage Class V, upon request Class VI



**TRUNNION 2 PCS
ZGMS**

 **400°C**
↑ Up to 640°C with F stem Extension

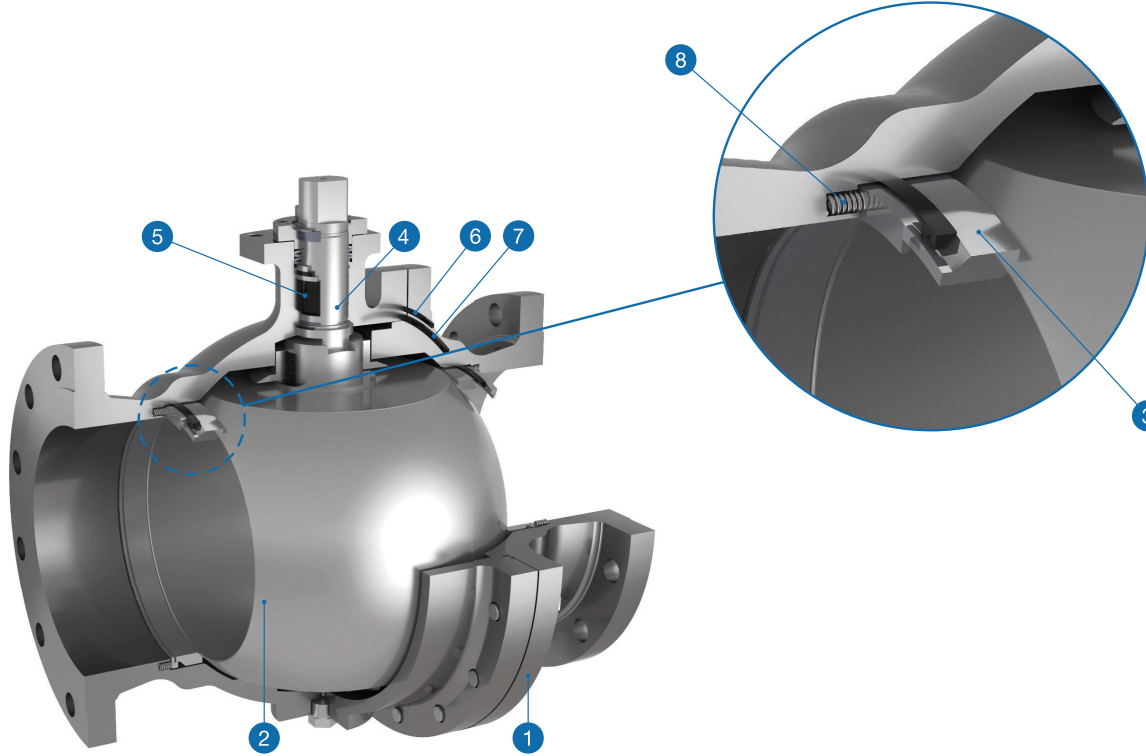

Standard Materials

Item	Description	ANSI*		DIN*	
		Carbon steel	Stainless steel	Carbon steel	Stainless steel
1	Body	A216WCC / A352 LCC	A351 CF8M	1.0619 / 1.6220	1.4408
2	Ball	CF8M + Cr-Carbide		1.4408 + Cr-Carbide	
3	Seat	AISI 316 + Cr-Carbide		1.4401 + Cr-Carbide	
4	Stem	XM-19		XM-19	
5	Stem packing 2	Graphite		Graphite	
6	Body Seal 1	Graphite		Graphite	
7	Body Seal 2	Graphite		Graphite	
8	Spring Seat	Inconel X750		Inconel X750	

* Other material construction for different service upon request

Range

ZMS	
SIZE	RATING
DN40-300	PN10-16
DN40-200	PN10-40
1 1/2" - 12"	Class 150
1 1/2" - 8"	Class 300

General Features

- Trunnion / DBB
- Split body
- Full bore
- Bidirectional
- Anti blow out stem
- Auto-adjustable packing
- Antistatic device
- Self-cavity pressure relief
- Spring loaded seats
- Leakage Class V, upon request Class VI



TRUNNION 3 PCS
ZGKMS / ZGKMSRB

 **400°C**
↑ Up to 640°C with F stem Extension

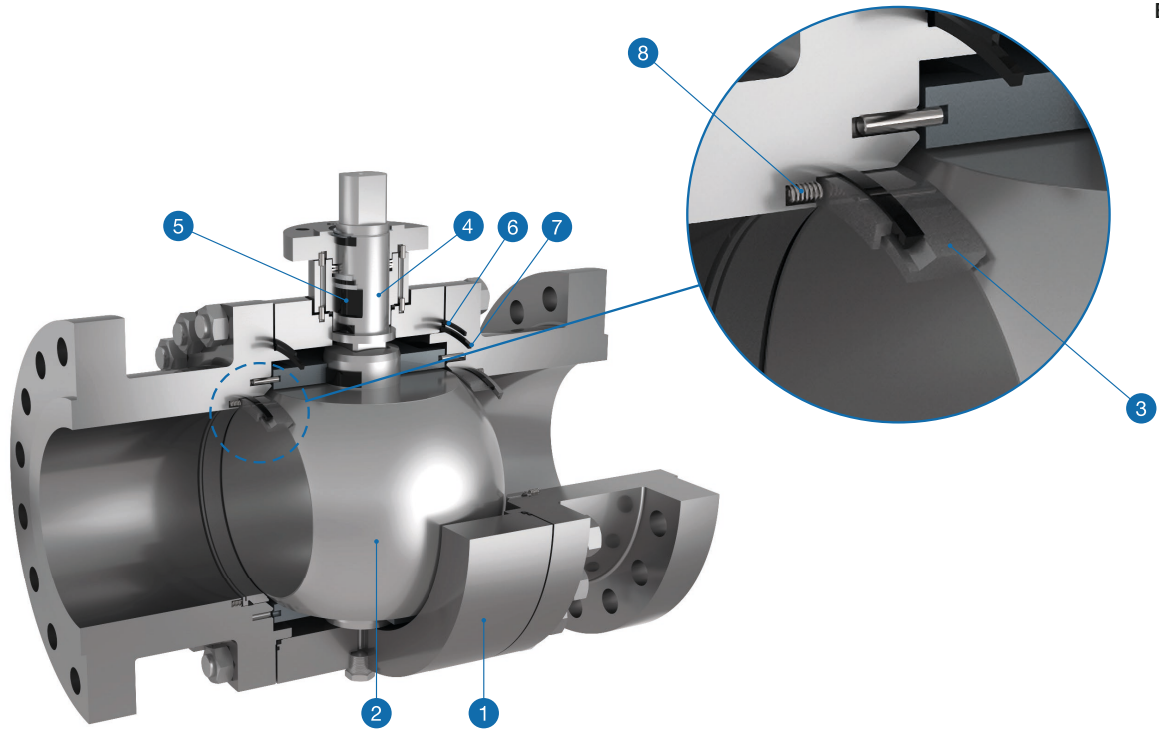

Standard Materials

Item	Description	ANSI*		DIN*	
		Carbon steel	Stainless steel	Carbon steel	Stainless steel
1	Body	A105/A350 LF2	A182 F316	1.0352	1.4401
2	Ball	F316 + Cr-Carbide/XM-19 + Cr-Carbide		1.4401+Cr-Carbide/XM-19	
3	Seat	F316 + Cr-Carbide/XM-19 + Cr-Carbide		1.4401 + Cr. Carbide	
4	Stem	XM-19		XM-19	
5	Stem packaging 2	Graphite		Graphite	
6	Body Seal 1	Graphite		Graphite	
7	Body Seal 2	Graphite		Graphite	
8	Spring Seat	Inconel X750		Inconel X750	

* Other material construction for diferent service upon request

Range

ZMS	
SIZE	RATING
DN 15 - 1050	PN 10 - 100
DN 15 - 500	PN 160 - 250
DN 15 - 300	PN 320 - 400
1/2" - 42"	Class 150 - 600
1/2" - 20"	Class 900 - 1500
1/2" - 12"	Class 2500

General Features

- Trunnion / DBB
- 3 Pieces body.
- Full / Reduced bore.
- Bidirectional.
- Anti blow out stem.
- Auto-adjustable packing.
- Antistatic device.
- Self-cavity pressure relief.
- Spring loaded seats.
- Leakage Class V, upon request Class VI



**TOP ENTRY FLOATING
ZETEMS / ZETEMSRB**

 **400°C**
↑ Up to 640°C with F stem Extension

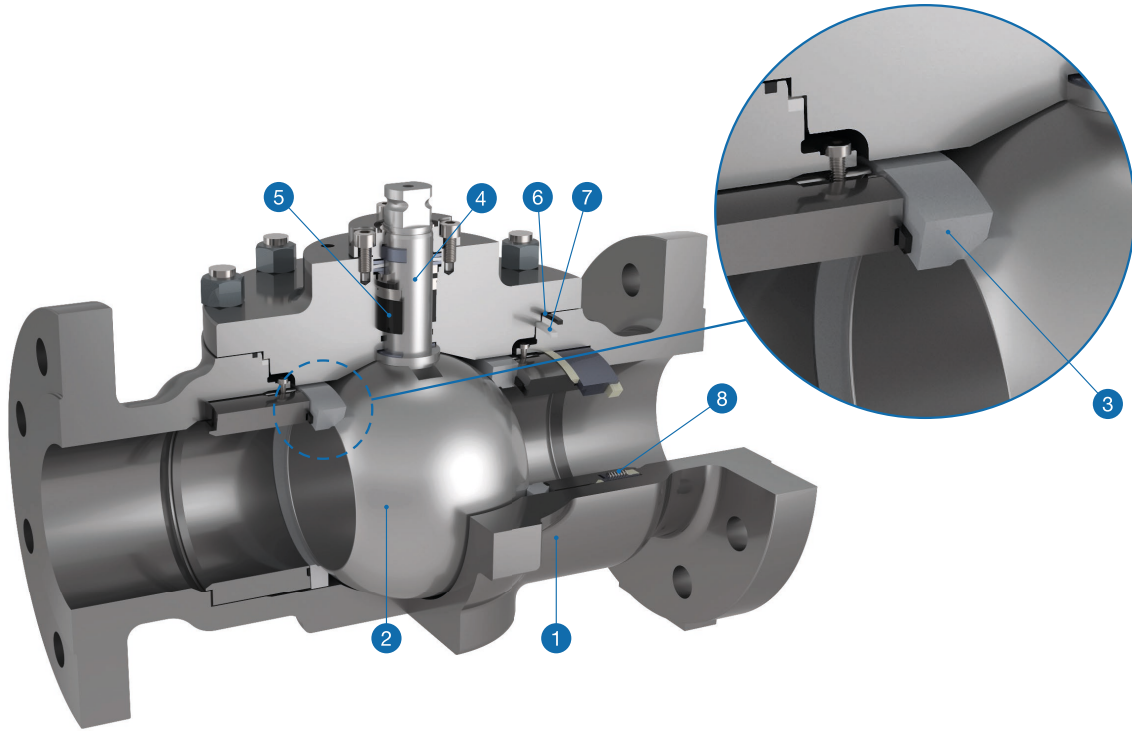

Standard Materials

Item	Description	ANSI*		DIN*	
		Carbon steel	Stainless steel	Carbon steel	Stainless steel
1	Body	A216 WCC / A352 LCC	A351 CF8M	1.0619 / 1.6620	1.4408
2	Ball	F316 + Cr. carbide		1.4401 + Cr. Carbide	
3	Seat	AISI 316 + Cr. Carbide		1.4401 + Cr. Carbide	
4	Stem	XM-19		XM-19	
5	Stem packing 2	Graphite		Graphite	
6	Body Seal 1	Graphite		Graphite	
7	Body Seal 2	Graphite		Graphite	
8	Spring Seat	Inconel X750		Inconel X750	

* Other material construction for different service upon request

Range

ZETEMS	
SIZE	RATING
DN15-100	PN 16 - 40
DN15-50	PN 63 - 100
1/2" - 8"	Class 150
1/2" - 4"	Class 300
1/2" - 2"	Class 600

General Features

- Floating Ball
- Top Entry
- Full / Reduced Bore
- Bidirectional
- Anti blow out stem
- Auto-adjustable packing
- Antistatic device
- Self-cavity pressure relief
- Allows in-line maintenance
- Spring loaded seats
- Leakage Class V, upon request Class VI



TOP ENTRY TRUNNION
ZETEGMS / ZETEGMSRB

 **400°C**
↑ Up to 640°C with F stem Extension

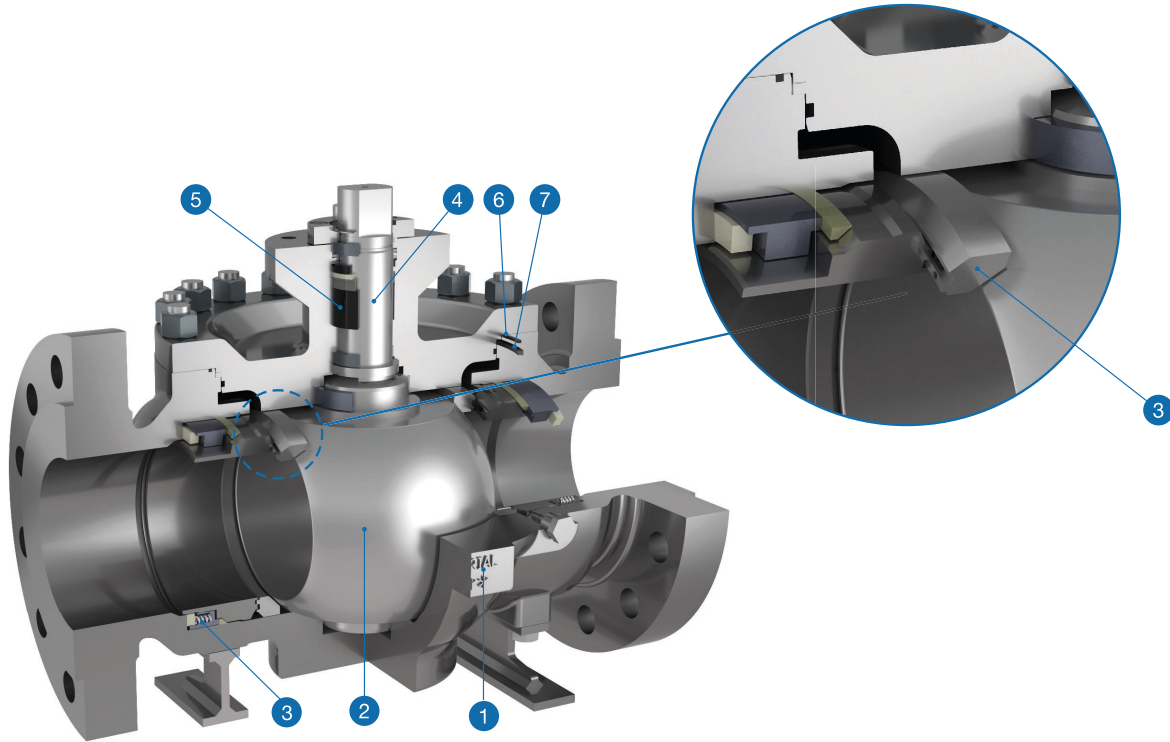

Standard Materials

Item	Description	ANSI*		DIN*	
		Carbon steel	Stainless steel	Carbon steel	Stainless steel
1	Body	A216WCC/ A352 LCC	A351 CF8M	1.0619/1.6620	1.4408
2	Ball	F316 + Cr. Carbide		1.4401 + Cr. Carbide	
3	Seat	AISI 316 + Cr. Carbide		1.4401 + Cr. Carbide	
4	Stem	XM-19		XM-19	
5	Stem packing 2	Graphite		Graphite	
6	Body Seal 1	Graphite		Graphite	
7	Body Seal 2	Graphite		Graphite	
8	Spring Seat	Inconel X750		Inconel X750	

* Other material construction for different service upon request

Range

ZTEGMS	
SIZE	RATING
DN80 - 1050	PN 10-100
DN80 - 500	PN 160 - 250
DN80 - 300	PN 320-400
3" - 42"	Class 150 - 600
3" - 20"	Class 900 - 1500
3" - 12"	Class 2500

General Features

- Top Entry
- Trunnion / DBB
- Full / Reduced Bore
- Bidirectional
- Anti blow out stem
- Auto-adjustable packing
- Antistatic device
- Self-cavity pressure relief
- Allows in-line maintenance
- Spring loaded seats
- Leakage Class V, upon request Class VI



3 PCS
ZKMS / ZKMSRB

 **400°C**
↑ Up to 640°C with F stem Extension

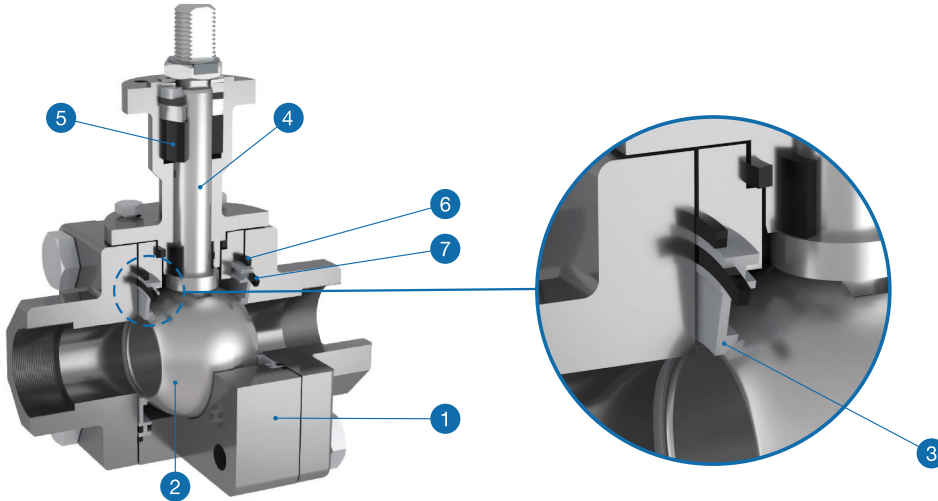

KMV / KMVRB

 **220°C**

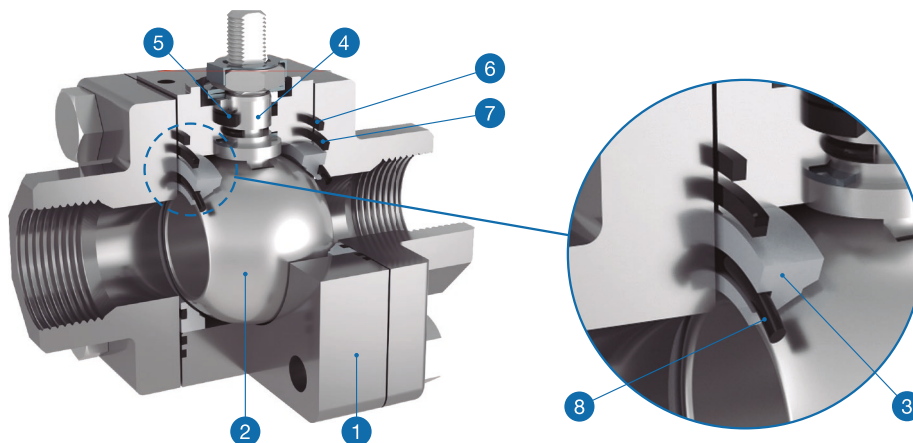

Standard Materials

Item	Description	ANSI*		DIN*	
		Carbon steel	Stainless steel	Carbon steel	Stainless steel
1	Body	A182 F316/316L	A105/A350 LF2	A182 F316/316L	A105/A350 LF2
2	Ball	F316/F316L		F316/F316L + Cr-Carbide	
3	Seat	AISI 316 + F51		AISI 316 + Cr-Carbide	
4	Stem	XM-19		XM-19	
5	Stem packing 2	Graphite		Graphite	
6	Body Seal 1	Graphite		RPTFE	
7	Body Seal 2	Graphite		Graphite	
8	O-ring	-		FKM	

* Other material construction for different service upon request

Range

ZMS	
SIZE	RATING
1/4" - 4"	Class 150
1/4" - 1"	Class 800

General Features

- 3 PCS Body
- Full / Reduced Bore
- Bidirectional
- Antistatic device
- Anti blow out stem
- Auto-adjustable packing
- Self-cavity pressure relief
- Spring loaded seats
- Leakage Class V, upon request Class VI



SEATS DESIGN

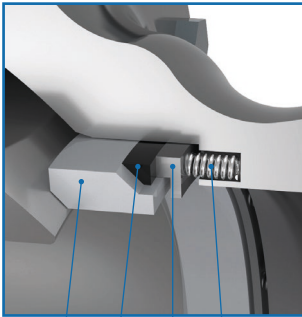

47 108 48 45

Spring Loaded High Temperature

Item	Description
108	Seat Seal
45	Spring Seat
47	Metal Seat
48	Ring Seat

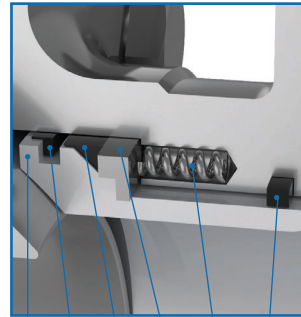

47 46b 46a 44b 45 46c

Protected Dust Proof

Item	Description
47	Metal Seat
46c	Seat Seal 3
46b	Seat Seal 2
46a	Seat Seal 1
45	Spring Seat
44b	Ring Seat

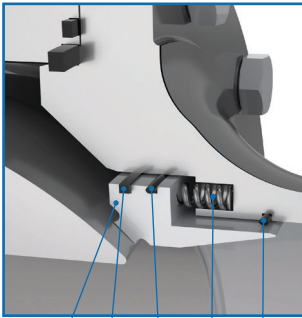

47 46 108 45 108

Protected and Scraper Sticky Material

Item	Description
108	Seat Seal 2
47	Metal Seat
46	Seat Seal 1
45	Spring Seat

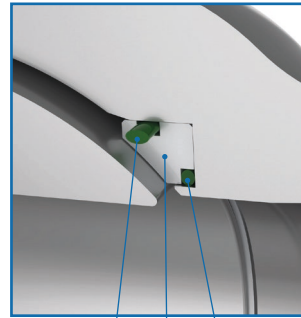

108 47 48

Pulp & Paper

Max. Temp: FKM up to 220°C
Max. Temp: FKM up to 327°C

Item	Description
108	O-ring Seat
48	O-ring spring Seat
47	Metal Seat

STEM EXTENSIONS



Simple

- Length 150 mm.
- Only Lever Operated.
- No Stem Packing.
- No gasket between valve & Stem extension.
- Manufactured from bar material.

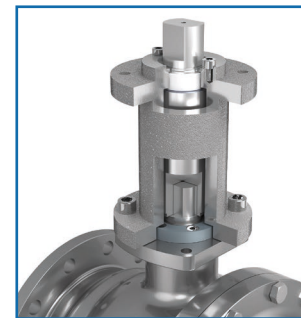

Standard Z

- Length 150mm.
- Top Flange ISO 5211
- No Stem Packing.
- No gasket between valve & Stem extension.
- Stem guide seal on top.
- Housing in cast material.

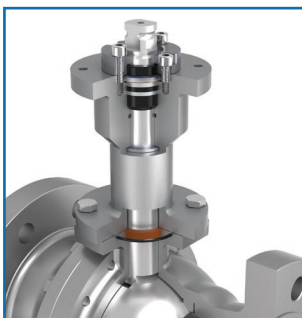

Security F

- High Temperature & Low emission
- Length 150 mm.
- Top Flange ISO 5211
- Stem Packing on Top, no packing in valve.
- Gasket between valve & Stem extension.

Up to 640°C

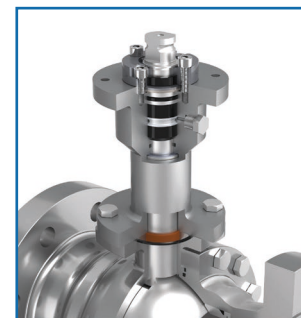

Security F with Fugitive Detector (F1)

- High Temperature & Low emission
- Length 150 mm.
- Top Flange ISO 5211
- Double stem packing
- Gasket between valve & stem extension.
- Grease injector or fugitive detector between the two packings in the stem extension.

Up to 640°C



Metal Seated



**FLOATING
ZMV**



**TRUNNION
2PCS ZGMS**

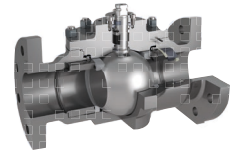

**TOP ENTRY
FLOATING ZETEMS**

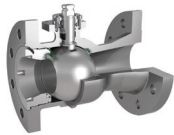

**FLOATING
ZMVRB**

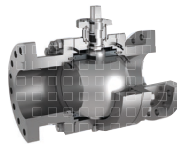

**TRUNNION
3PCS ZGKMS**

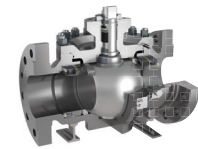

**TOP ENTRY
TRUNNION ZETEGKMS**

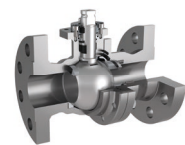

**FLOATING
ZMS**



**3PCS
ZKMS**



**3PCS
KMV**