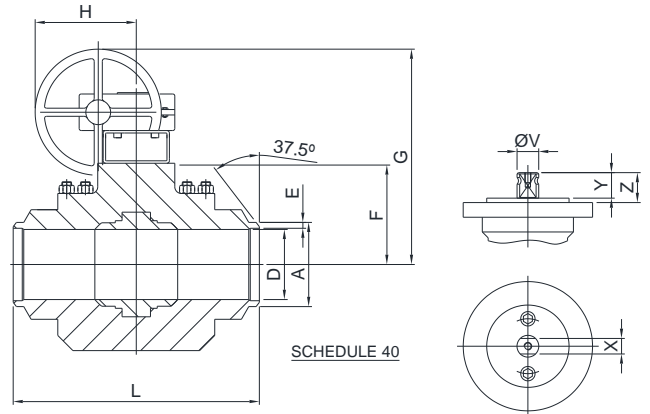
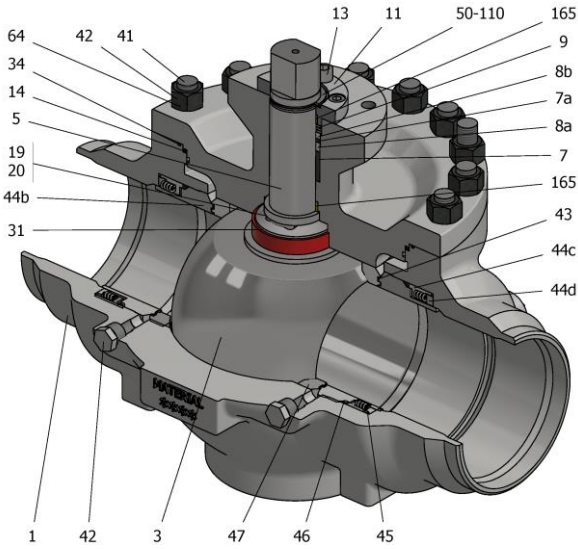

FIG.ZTEGMS 69 CGGG CL600 6"-12" BW (Sch.40)



Position	Description	Material
01	Body 1	C.S. A352 LCC
03	Ball	AISI 316+Cr-Carbide
05	Stem	XM-19
07	Stem packing	Graphite
07a	Stem packing 2	Graphite
08a	Gland packing 1	S.S. AISI 316
08b	Gland packing 2	S.S. AISI 316
09	Spring washer	Inconel X718
11	Cover	A351 CF8M/AISI 316
13	Cover bolt	S.S. (316)
14	Body seal 1	Graphite
19	Spring	S.S. AISI 316
20	Antistatic ball	S.S. AISI 316
31	Bearing	Carbongraphite
34	Body seal 2	Graphite
41	Stud	A320 L7M
42	Nut	A194 7M
43	Seat seal	Graphite+AISI 316
44b	Ring seat 2	S.S. AISI 316
44c	Ring seat 3	S.S. AISI 316
44d	Ring seat 4	S.S. AISI 316
45	Spring	Inconel X750
43	Seat seal	Graphite
47	Metal seat	S.S. AISI 316
50	Subjection ring	S.S. AISI 420
64	Body cover	C.S. A352 LCC
86	Plug	C.S. A350 LF2
110	Subjection ring seal	S.S. AISI 316 Nitrided
165	Stem bearing	Carbongraphite

General features

- Full trunnion.
- Top entry
- Full bore.
- Metal to Metal.
- Bidirectional.
- Spring loaded seat system.
- Anti Blow out proof stem.
- Anti static device.
- Self-cavity pressure relief.
- Double Block and Bleed.
- Allows in-line maintenance

Standards

- Top flange ISO 5211
- Buttwelding ends B16.25
- Face to face ANSI B16.10
- Testing API 598, API 6D, BS 6755-1
- Design API 6D, B16.34
- Materials according to NACE MR0175

Official approvals

- CERTIFICATE FIRE SAFE
- TA-LUFT VDI 2440
- ISO 15848-1
- ATEX 2014/34/EU API 6D.
- PED 2014/68/EU
- SIL 3 CAPABLE

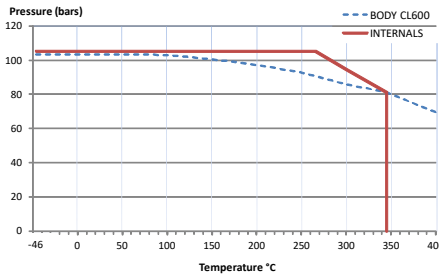

PEKOS GROUP CERTIFICATES:



DIMENSIONS & Technical information

DN	CL	D	L	E	A	B	C	F	H	G	V	X	Y	Z	n x d	ISO 5211	Torque	MAST	Weight
6"	600	150	559	7,11	168,3	-	-	236	336	608	48	36	40	63	- x -	F16-1	1110	4716	176
8"	600	201	660	8,18	219,1	-	-	279	436	657	48	36	40	73	- x -	F16	1750	9360	321
10"	600	252	787	9,27	273	-	-	310	436	688	60	46	60	68	- x -	F25-1	2215	9360	457
12"	600	303	838	10,31	323,8	-	-	383	461	688	72	55	70	83	- x -	F25	2640	16131	670

** Depending on service conditions. * Dimensions are in mm. * Torque & MAST are in Nm * Weight is in Kilograms
* Torque values have been measured ΔP at maximum rating at room temperature