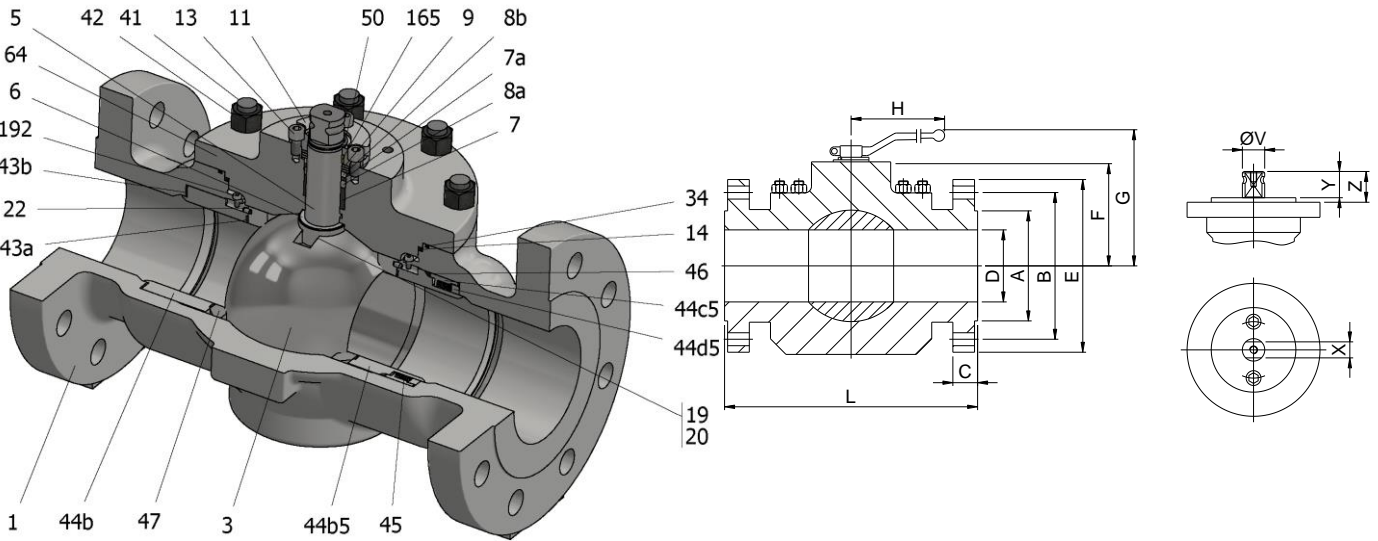

FIG.ZTEMS 64 CGGG CL600 1"-2"



Position	Description	Material
01	Body 1	C.S. A216 WCC
03	Ball	AISI 316+Cr-Carbide
05	Stem	XM-19
06	Stem seal	S.S. AISI 316 Nitrided
07	Stem packing	Graphite
07a	Stem packing 2	Graphite
08a	Gland packing 1	S.S. AISI 316
08b	Gland packing 2	S.S. AISI 316
09	Spring washer	Inconel X718
11	Cover	S.S. A351 CF8M
13	Cover bolt	S.S. (316)
14	Body seal 1	Graphite
16	Handle	A351 CF8M/WCB
17	Handle bolt	S.S. (304)/1.045(8.8)
19	Spring	S.S. AISI 316
20	Antistatic ball	S.S. AISI 316
22	Stop pin	S.S. AISI 316
34	Body seal 2	Graphite
41	Stud	A320 L7M
42	Nut	A194 7M
43a	Seat seal 1	Graphite+AISI 316
43b	Seat seal 2	Graphite+AISI 316
44b	Ring seat 2	S.S. AISI 316
44b5	Ring seat 2 (spring)	S.S. AISI 316
44c5	Ring seat 4 (spring)	S.S. AISI 316
44d5	Ring seat 3 (spring)	S.S. AISI 316
45	Spring	Inconel X750
47	Metal seat	S.S. AISI 316
50	Subjection ring	S.S. AISI 316
64	Body cover	C.S. A216 WCC
165	Stem bearing	Carbongraphite
192	Positioner bolt	S.S. (316)

General features

- Floating ball.
- Top entry
- Full bore.
- Metal to Metal.
- Bidirectional.
- Anti Blow out proof stem.
- Anti static device.
- Self-cavity pressure relief.
- Allows in-line maintenance

Standards

- Top flange ISO 5211
- Flanges ANSI B16.5
- Face to face ANSI B16.10
- Testing API 598, API 6D, BS 6755-1
- Design API 6D, B16.34
- Materials according to NACE MR0175

Official approvals

- CERTIFICATE FIRE SAFE
- TA-LUFT VDI 2440
- ISO 15848-1
- API 6D.
- ATEX 2014/34/EU
- PED 2014/68/EU
- SIL 3 CAPABLE

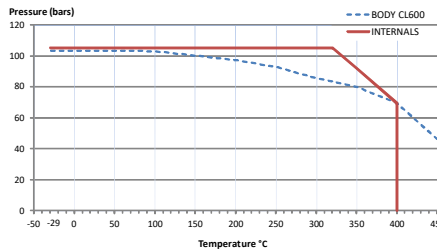

PEKOS GROUP CERTIFICATES:

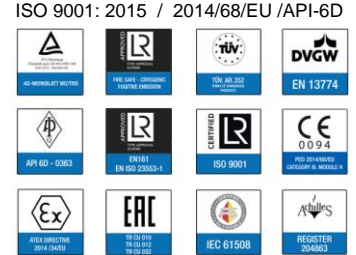

DIMENSIONS & Technical information

DN	CL	D	L	E	A	B	C	F	H	G	V	X	Y	Z	n x d	ISO 5211	Torque	MAST	Weight
1"	600	25	216	125	51	89	25	67	185	124	18	14	17	19,5	4 x 19	F05	100	175	10
1 1/4"	600	32	229	135	64	98	28	71	185	128	18	14	17	19,5	4 x 19	F05	228	175	13
1 1/2"	600	40	241	155	73	114	30	87	293	157	22	17	20	30	4 x 22	F07	309	464	18
2"	600	50	292	165	92	127	33	95	293	165	22	17	20	30	8 x 19	F07	390	464	26

** Depending on service conditions. * Dimensions are in mm. * Torque & MAST are in Nm * Weight is in Kilograms
 * Torque values have been measured ΔP at maximum rating at room temperature